

~~TOP SECRET~~
~~SECURITY INFORMATION~~

ADC-TSCO 120A

AIR DEFENSE COMMAND BRIEFING

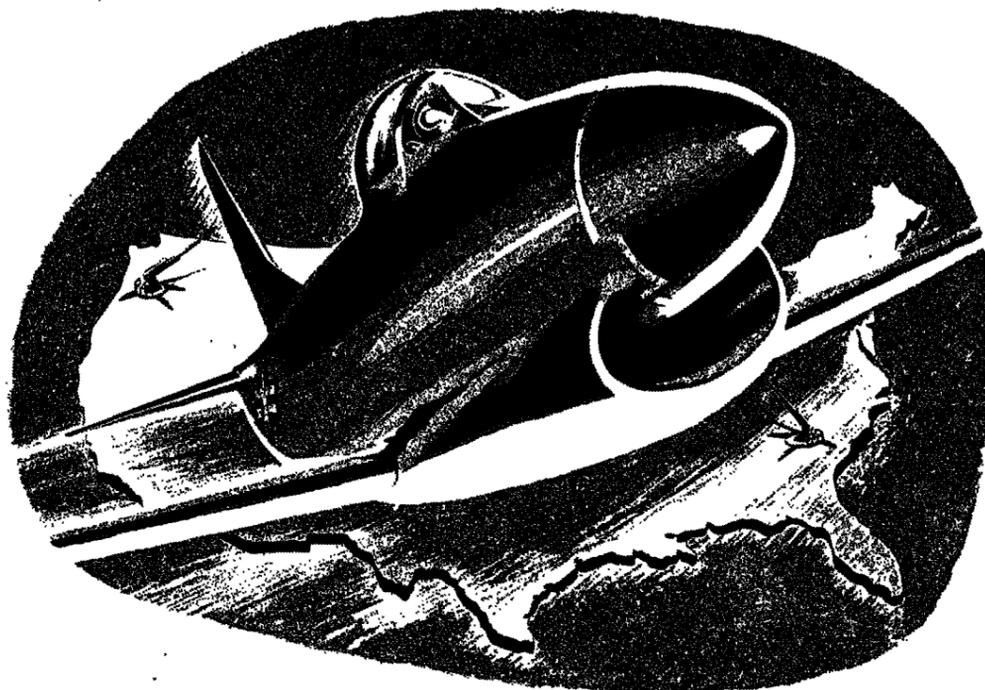

Declassified and approved for release by NSA on 09-03-2014 pursuant to E.O. 13526

AIR DEFENSE COMMAND · ENT AIR FORCE BASE
COLORADO SPRINGS · COLORADO

REVISED APRIL 1953

~~TOP SECRET~~
~~SECURITY INFORMATION~~

This is copy No. 89 of 100 copies.

~~top secret~~

BY AUTH: CG · ADC
INITIALS: *red*
DATE:

This Document CONTAINS INFORMATION
AFFECTING THE NATIONAL DEFENSE OF THE UNITED STATES WITH-
IN THE MEANING OF THE ESPIONAGE LAWS, TITLE 18 U.S.C., SEC-
TIONS 793 AND 794. ITS TRANSMISSION OR THE REVELATION OF
ITS CONTENTS IN ANY MANNER TO AN UNAUTHORIZED PERSON IS
PROHIBITED BY LAW.

RETAIN OR DESTROY IN ACCORDANCE WITH AFR 205-1.

DO NOT RETURN

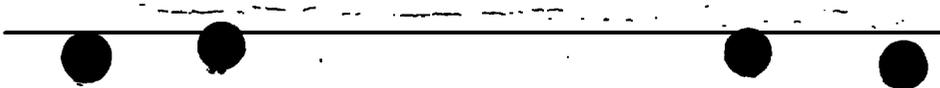

~~TOP SECRET — SECURITY INFORMATION~~

FOREWORD

THE PURPOSE OF THIS DOCUMENT IS TO GIVE THE READER A BROAD UNDERSTANDING OF THE PRESENT AIR DEFENSE SYSTEM, INCLUDING STATUS TODAY, PROGRAMS, AND GENERAL PLANS.

THE INFORMATION CONTAINED HEREIN IS CURRENT AS OF APRIL 1953. AMENDMENTS WILL NOT BE PUBLISHED AS CHANGES OCCUR.

~~TOP SECRET — SECURITY INFORMATION~~

~~TOP SECRET~~ — ~~SECURITY INFORMATION~~
I N D E X (Contd)

PAGE	TITLE	CLASSIFICATION	
		COMMENTARY	CHART
35	Current Fighter Deployment	SECRET	SECRET
36	Fighter Aircraft Inventory	SECRET	SECRET
37	FY 55 Fighter Program (By Type)	SECRET	SECRET
38	ANG Backup	SECRET	SECRET
39	Interceptor Armament	SECRET	SECRET
40	Programmed AA Defenses	SECRET	SECRET
41	Present AA Defenses	SECRET	SECRET
42	NIKE	SECRET	Uncl
43	Electronic Countermeasures	SECRET	SECRET
44	Decentralization Control	SECRET	SECRET
45	Air Defense Warning	Uncl	Uncl
46	Civil Air Defense Warning	Uncl	Uncl
47	CONELRAD	RESTRICTED	Uncl
48	Wire I	SECRET	Uncl
49	Wire II	SECRET	Uncl
50	Weather in Air Defense	Uncl	Uncl
51	Air Defense Exercises	SECRET	Uncl
52	Operational Statistics	SECRET	Uncl
53	Present Boundaries	RESTRICTED	RESTRICTED
54	1955 ██████████	SECRET	SECRET
55	Command & Operations	RESTRICTED	Uncl
56	Panorama	SECRET	SECRET
57	Kill vs Cost	TOP SECRET	TOP SECRET
58	Future Threat	TOP SECRET	TOP SECRET
59	Future Surveillance	TOP SECRET	TOP SECRET
60	Future Weapons (F-102)	CONFIDENTIAL	Uncl
61	Future Weapons (F-103)	CONFIDENTIAL	Uncl
62	Future Weapons (Bomarc)	SECRET	Uncl
63	Future Weapons (Local Types)	SECRET	SECRET
64	How Much Air Defense	SECRET	SECRET
65	Forces Required in Future	SECRET	SECRET
66	Future Cost	SECRET	SECRET
67	Ballistics Threat	SECRET	Uncl



AIR DEFENSE CONTINENTAL UNITED STATES

~~SECURITY INFORMATION~~~~SECRET~~THREAT TODAY

THE MAJOR THREAT WE FACE TODAY IS CERTAINLY OBVIOUS -- THE SOVIET AIR FORCE IS A HIGHLY ORGANIZED AND VERSATILE COMPLEX OF AIR FORCES, ARMED WITH FIRST CLASS EQUIPMENT. THIS FORCE IS SUPPORTED BY A MASSIVE INDUSTRIAL AND RESEARCH STRUCTURE OVER WHICH IT EXERCISES THE HIGHEST PRIORITIES. THEY HAVE MOVED A LONG WAY IN OVERCOMING THEIR DEFICIENCY IN LONG RANGE AIR POWER. TODAY, THE COMMANDER OF THE SOVIET LONG RANGE AIR FORCE HAS AT HIS DISPOSAL SEVERAL HUNDRED TU-4's -- THE IMPROVED SOVIET ADAPTATION OF OUR B-29. HIS FORCE IS CONTINUING TO EXPAND AND IS IMPROVING IN PERFORMANCE AND CAPABILITY. ALONG WITH THIS RAPID RISE IN LONG RANGE AIR POWER IS THE COMPANION RISE OF SOVIET ATOMIC POWER. TOGETHER THEY FORM THE MOST OMINOUS THREAT THIS COUNTRY HAS EVER KNOWN.

AS OF NOW, WE ESTIMATE THE SOVIET UNION IS CAPABLE OF MASS RAIDS ON THE UNITED STATES WITH AS MANY AS FOUR HUNDRED TU-4's CARRYING POSSIBLY ONE HUNDRED A-BOMBS. BY 1955 THIS THREAT MAY WELL BE 1000 AIRCRAFT AND 500 A-BOMBS.

TO COUNTER THIS THREAT REQUIRES THE COORDINATED EFFORT OF ALL OF US -- MILITARY AND CIVILIAN. TODAY, WARS ARE FOUGHT BY THE PEOPLE AS A WHOLE -- NOT MERELY BY MILITARY FORCES. CIVIL DEFENSE PROGRAMS MUST GO HAND-IN-HAND WITH THE MILITARY PROGRAMS. WE MAY HOPE FOR THE BEST -- BUT WE MUST BE PREPARED FOR THE WORST.

2

~~SECRET~~~~SECURITY INFORMATION~~

SOVIET AF CAPABILITY



~~SECURITY INFORMATION~~~~SECRET~~CRITICAL AREAS

SHOWN HERE ARE THE CRITICAL AREAS TO BE DEFENDED. THE SELECTION OF THESE AREAS WAS BASED UPON MANY FACTORS, INCLUDING:

- A. THE CANADA-U.S. EMERGENCY DEFENSE PLAN, WHICH LISTS AREAS 1, 2, AND 3 AND THE CENTRAL NEW MEXICO PORTION OF AREA 5 AS CRITICAL AREAS.
- B. THE AIR FORCE EMERGENCY WAR PLAN WHICH ALSO INCLUDES ATOMIC INSTALLATIONS AND STRATEGIC AIR COMMAND BASES AS CRITICAL TARGETS.
- C. THE CONSENSUS OF ESTIMATES OF USSR INTENTIONS.
- D. THE MANNER OF ATTACK; THAT IS, BOTH HIGH AND LOW ALTITUDES.
- E. THE LIMITED DEFENSE FORCES AVAILABLE.

THE DECISION WAS MADE TO ESTABLISH AREAS FOR AIR DEFENSE WITH HIGHER PRIORITY ON THOSE AREAS WHEREIN DESTRUCTION OF POPULATION, GOVERNMENT AND INDUSTRY WOULD HURT THE UNITED STATES MOST IN A PROTRACTED WAR; AND THAT ANY OTHER CRITICAL TARGETS OUTSIDE OF THESE PRIMARY AREAS WOULD OF NECESSITY BE AFFORDED LESSER DEGREE OF PRIORITY. THE RESULTANT AREA PRIORITY LIST IS AS FOLLOWS: AREAS 1, 2 AND 3 ARE ASSIGNED PRIORITY "A". AREAS 4, 5 AND 6, PRIORITY "B". AREA 7 AND THE REMAINING SCATTERED SMALL AREAS SHOWN, PRIORITY "C". THE REMAINDER OF THE COUNTRY, PRIORITY "D".

THIS DOES NOT MEAN THAT AREAS 1, 2, AND 3 WILL BE AFFORDED PROTECTION TO THE EXCLUSION OF EVERYTHING ELSE. IT DOES MEAN THAT WITH PROPER PLANNING AND PROGRAMMING BASED ON THIS PRIORITY LIST, MORE EFFECTIVE USE CAN BE MADE OF THE LIMITED FORCES NOW AVAILABLE AND THOSE PROGRAMMED FOR THE NEAR FUTURE.

THIS DETERMINATION OF PRIORITIES WAS MADE BY ADC. TO OUR KNOWLEDGE, NO TOP LEVEL DECISION HAS BEEN MADE AS TO PRIORITY OF AREAS FOR AIR DEFENSE.

³~~SECRET~~~~SECURITY INFORMATION~~

AIR DEFENSE COMMAND

SECRET

CRITICAL AIR DEFENSE AREAS

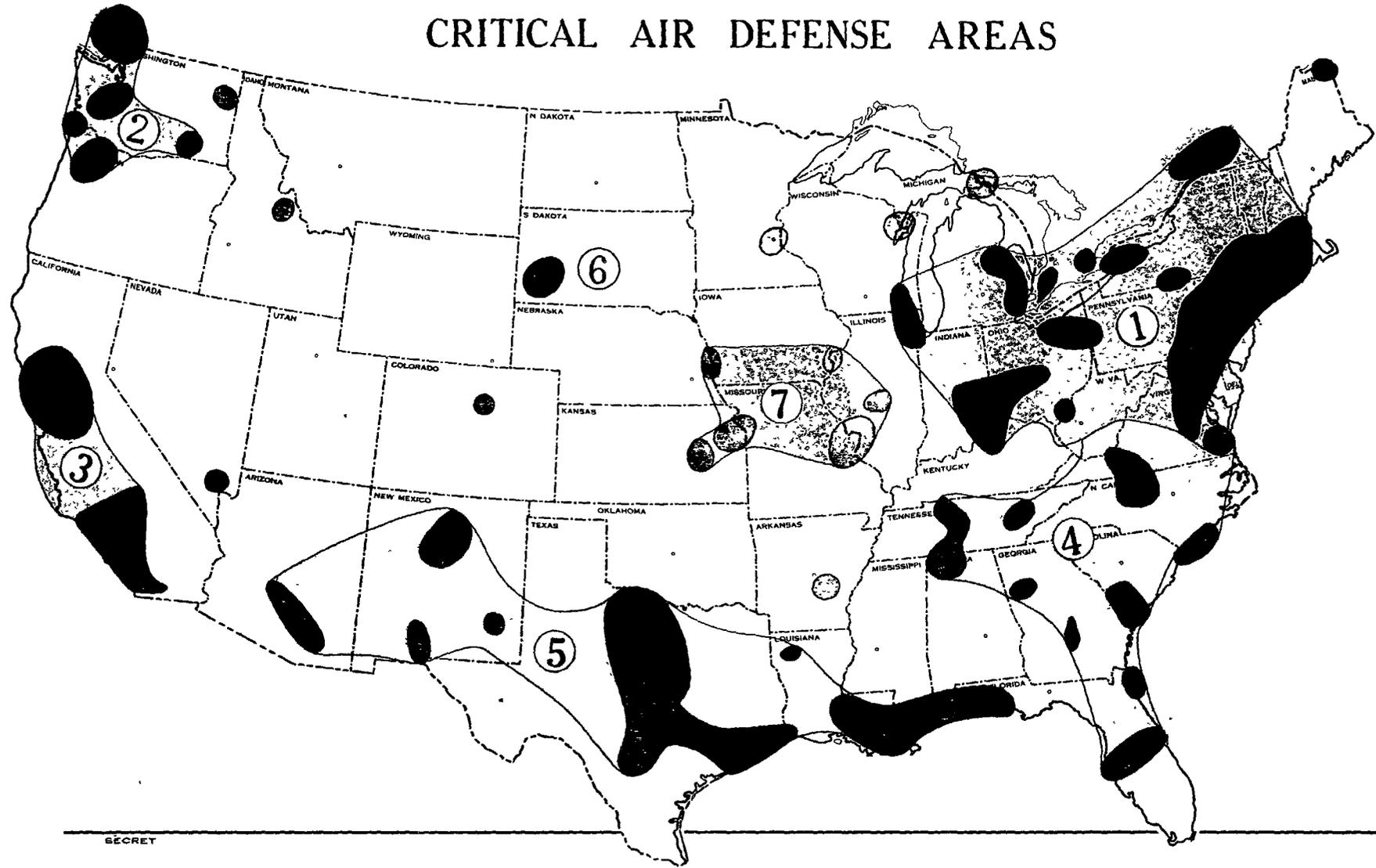

SECRET

AIR DEFENSE RESPONSIBILITIES

THIS OUTLINES THE RESPONSIBILITIES OF VARIOUS AGENCIES IN THE AIR DEFENSE OF THE UNITED STATES. THE AIR FORCE HAS BEEN GIVEN PRIMARY RESPONSIBILITY FOR THE AIR DEFENSE MISSION AND IS CHARGED, THEREFORE, WITH ACHIEVED REQUISITE COORDINATION WITH THE OTHER MEMBERS OF THE MILITARY FAMILY, AND WITH CIVILIAN AGENCIES WHICH EITHER HAVE A POTENTIAL FOR AUGMENTATION OF DEFENSE CAPABILITIES OR DIRECT OR INDIRECT RESPONSIBILITIES TOWARD THE PROTECTION OF OUR PEOPLE AND OUR INDUSTRY. THE AIR FORCE FURNISHES THE FIGHTER FORCE AND WILL FURNISH LONG RANGE AREA WEAPONS; IT FURNISHES THE BASIC GROUND ENVIRONMENT FOR SURVEILLANCE OF THE AIR, AND FOR THE CONTROL OF THE WEAPONS WHICH ARE PROVIDED; IT INITIATES THE WARNINGS REQUIRED TO ALERT MILITARY AND CIVILIAN COMPONENTS; AND IT ESTABLISHES REQUIREMENTS ON OTHER SERVICES FOR PARTICIPATION IN THE AIR DEFENSE SYSTEM.

THE ARMY IS RESPONSIBLE FOR FURNISHING ANTI-AIRCRAFT FORCES FOR INCREASING THE DEFENSE OF VITAL TARGETS. SUCH FORCES, WHEN IN TACTICAL POSITION, COME UNDER THE BROAD OPERATIONAL CONTROL OF THE AIR FORCE.

THE NAVY FURNISHES AUGMENTATION FORCES AS REQUIRED, WITH THE GENERAL UNDERSTANDING THAT THESE WILL BE FORCES HAVING AN AIR DEFENSE CAPABILITY WHICH CAN BE INITIALLY SPARED FROM THE ACCOMPLISHMENT OF THE PRIMARY MISSION OF THE NAVY.

OTHER AGENCIES, SUCH AS THE FEDERAL CIVIL DEFENSE ADMINISTRATION, THE CIVIL AERONAUTICS ADMINISTRATION, AND THE FEDERAL COMMUNICATIONS COMMISSION, COORDINATE AND COOPERATE WITH THE AIR FORCE IN THE ESTABLISHMENT OF PROCEDURES, AND THE EXECUTION OF PLANS, DESIGNED TO PROVIDE FOR: AN ADEQUATE CIVIL DEFENSE, THE CONTROL OF CIVIL AIR TRAFFIC, AND THE CONTROL OF ELECTRONIC EMISSIONS.

AIR DEFENSE OF CONTINENTAL UNITED STATES

U.S. AIR FORCE - - - PRIMARY RESPONSIBILITY

U.S. ARMY - - - - - ANTI AIRCRAFT ARTILLERY

U.S. NAVY - - - - - FORCE AS REQUIRED

CIVIL AGENCIES - - - GOC, FCDA, CAA, FCC, *etc.*

~~SECURITY INFORMATION~~~~SECRET~~ADC - RCAF - AAC - NEAC RELATIONSHIPS

AT THIS TIME, I WOULD LIKE TO MENTION THE RELATIONSHIP BETWEEN CANADA AND THE UNITED STATES WITH RESPECT TO AIR DEFENSE AND OUR RELATIONSHIP WITH THE ALASKAN AIR COMMAND AND THE NORTHEAST AIR COMMAND. THE AIR DEFENSE COMMAND COORDINATES VERY CLOSELY WITH THE CANADIAN AIR DEFENCE COMMAND, AND THE RESPECTIVE AIR DEFENSE SYSTEMS OPERATE PRACTICALLY AS ONE. BUT THERE ARE LIMITATIONS WHICH MUST BE OBSERVED DUE TO INTERNATIONAL COMPLICATIONS. THERE ARE "TWO COORDINATED SYSTEMS" RATHER THAN "ONE INTEGRATED SYSTEM". OPERATIONAL CONTROL MUST BE MAINTAINED BY THE APPROPRIATE PERSONNEL OF THE COUNTRY IN, OR OVER WHICH, THE OPERATION IS TAKING PLACE.

THE ALASKAN AIR COMMAND AND THE NORTHEAST AIR COMMAND COORDINATE CLOSELY WITH ADC; BUT THE FULL CAPABILITIES OF THESE COMMANDS CAN NOT BE DIRECTLY APPLIED TO DEFENSE OF THE UNITED STATES. THE ENEMY CAN READILY AVOID THESE AREAS BY PROPER SELECTION OF ATTACK ROUTES.

IN THE BUILDING OF THE AIR DEFENSE SYSTEMS - LOGIC, PRIORITIES AND MEAGER MEANS DICTATED DEVELOPMENT FROM THE PRIME TARGETS OUTWARDS. THUS, WE EVOLVED ISLAND TYPE SYSTEMS SUCH AS ALASKA. EXPANSION OF THE SEPARATE SYSTEMS HAS NOW BROUGHT OUR PLANNING TO THE CONSIDERATION OF NORTH AMERICA AS A WHOLE. EVENTUALLY, THERE MUST BE ONE INTEGRATED AIR DEFENSE SYSTEM FOR THE WHOLE CONTINENT.

5

~~SECRET~~~~SECURITY INFORMATION~~

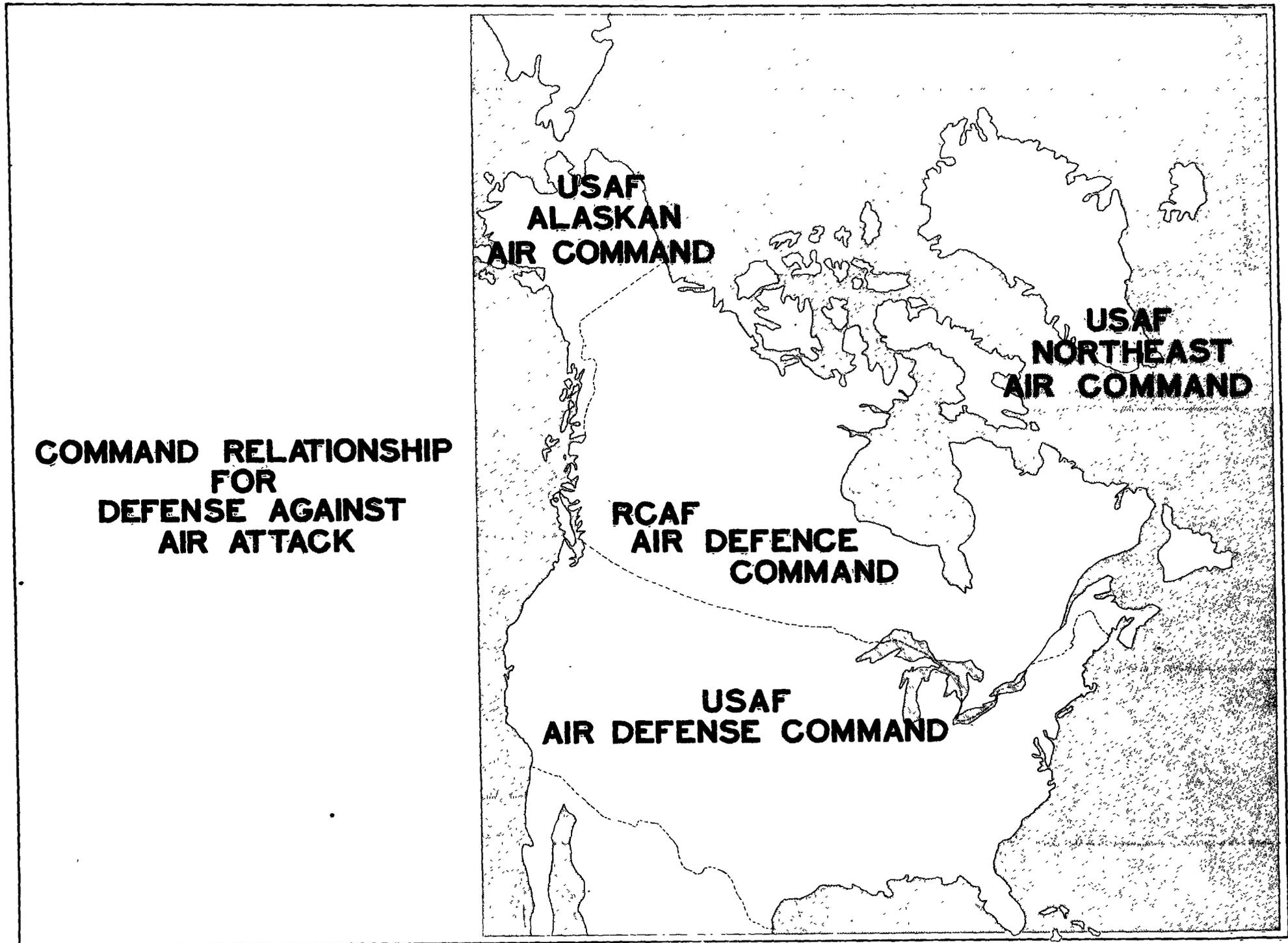

~~SECURITY INFORMATION~~~~RESTRICTED~~MISSION OF ADC

THE MISSION ASSIGNED THE AIR DEFENSE COMMAND IS TO:

- (1) PROVIDE AIR DEFENSE OF THE UNITED STATES.
- (2) SUPPORT THE EMERGENCY OPERATIONS OF STRATEGIC AIR COMMAND AND THE MILITARY AIR TRANSPORT SERVICE.
- (3) TO PARTICIPATE IN THE UNITED STATES AIR FORCE COLLATERAL MISSION OF ANTI-SUBMARINE WARFARE.

HOWEVER, CERTAIN ESSENTIAL GUIDANCE HAS YET TO BE PROVIDED TO ALLOW ADC TO PROPERLY ACCOMPLISH THIS MISSION. FOR EXAMPLE:

- A. THERE IS NO FULLY APPROVED PRIORITY LIST OF TARGETS TO BE DEFENDED.
- B. HOW MUCH AIR DEFENSE SHOULD WE PLAN FOR? SHOULD WE STRIVE FOR 50% KILL OR 95% KILL? FOR ONE THING - THE ECONOMICS OF THIS CANNOT BE EVALUATED BY ADC. GUIDANCE MUST COME FROM HIGHER ECHELONS OF OUR GOVERNMENT.

6

~~RESTRICTED~~~~SECURITY INFORMATION~~

ADC MISSION

1. PROVIDE AIR DEFENSE OF THE UNITED STATES.
2. SUPPORT EMERGENCY OPERATIONS OF SAC AND MATS.
3. PARTICIPATE IN USAF COLLATERAL MISSION OF ASW.

~~SECURITY INFORMATION~~~~RESTRICTED~~BASIC AIR DEFENSE ORGANIZATION

THIS CHART ILLUSTRATES THE ORGANIZATION OF THE AIR DEFENSE COMMAND AND THE ARMY ANTI-AIRCRAFT COMMAND FOR AIR DEFENSE OF THE CONTINENTAL UNITED STATES. THE AIR DEFENSE COMMAND, WITH ITS HEADQUARTERS IN COLORADO, HAS THREE MAJOR SUBORDINATE COMMANDS - THE EASTERN, CENTRAL, AND WESTERN AIR DEFENSE FORCES. EACH OF THESE DEFENSE FORCES IS FURTHER SUBDIVIDED INTO AIR DIVISIONS. THE ORGANIZATION OF THE ARMY ANTI-AIRCRAFT COMMAND IS GENERALLY PARALLEL. WHILE NOT SHOWN ON THE CHART, THE CLOSE ASSOCIATION HERE DEPICTED IS CARRIED ON DOWN THROUGH THE LOWER ECHELONS, WITH AA BRIGADES OR GROUPS WORKING WITH AIR DIVISIONS, AND BATTALIONS WORKING WITH ASSOCIATED AIR CONTROL AND WARNING SQUADRONS.

THE RELATIONSHIP AT ALL ECHELONS IS INTIMATE, WITH COMMON DOCTRINE AND COMMON UNDERSTANDING. RULES OF ENGAGEMENT ARE WORKED OUT MUTUALLY WITH THE AIM OF ACHIEVING THE OPTIMUM FROM ALL WEAPONS AVAILABLE.

AT PRESENT, THE ARMY AND THE AIR FORCE HAVE AN ORGANIZATION WITH FORCES SPECIFICALLY ASSIGNED FOR AIR DEFENSE OF THE UNITED STATES. THE U. S. NAVY COOPERATES IN PROVIDING FORCES WHEN AVAILABLE, THROUGH THE TWO SEA FRONTIER HEADQUARTERS. COORDINATION IS ESTABLISHED; AND STANDING OPERATING PROCEDURES ARE TESTED FREQUENTLY IN JOINT EXERCISES.

7

~~RESTRICTED~~~~SECURITY INFORMATION~~

ORGANIZATION - GEOGRAPHICAL SUBDIVISIONS

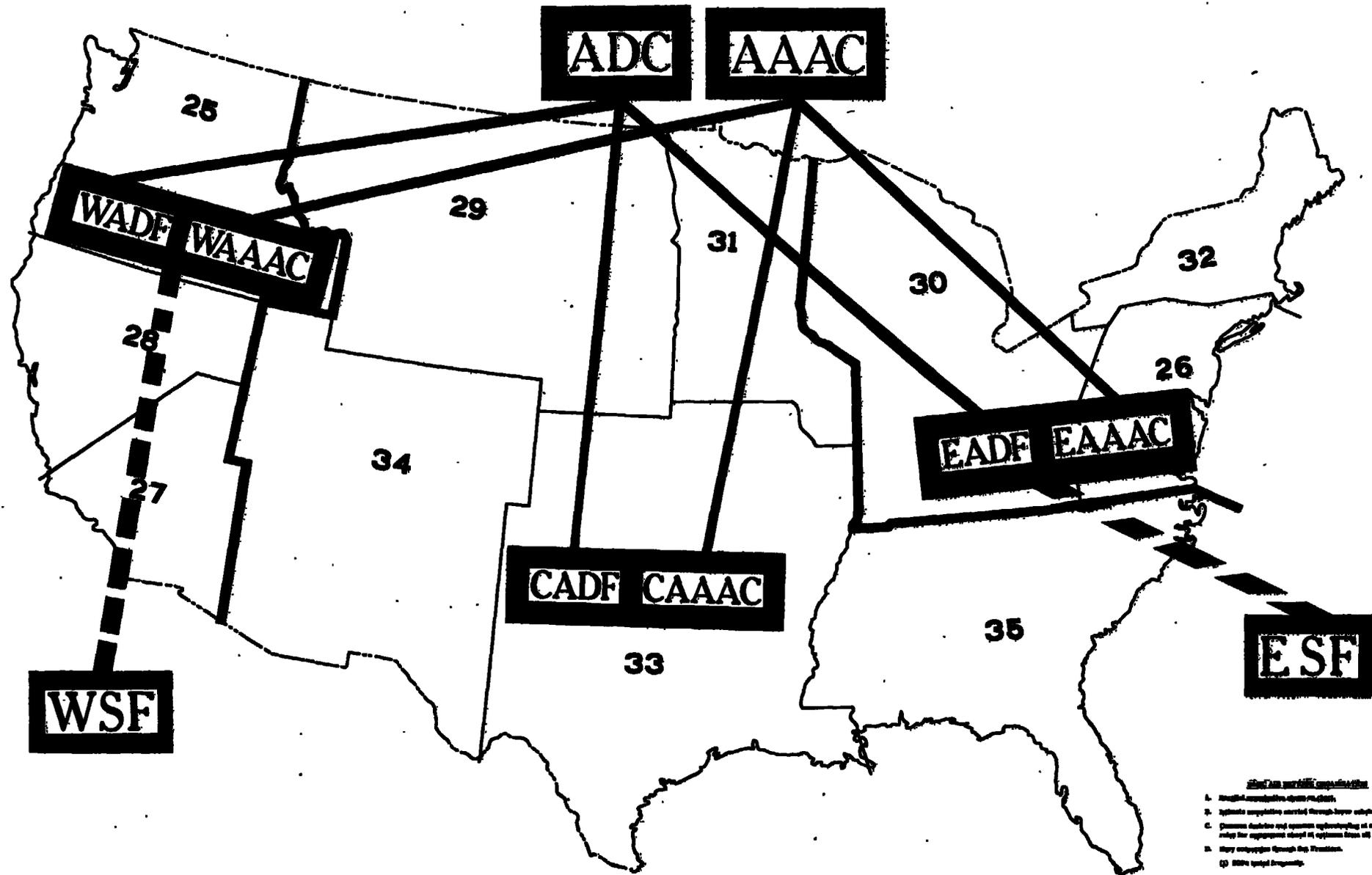

- Legend for symbols used in this diagram:*
- A. Straight lines indicate direct reporting.
 - B. Dashed lines indicate reporting through a third party.
 - C. Double lines indicate reporting through a second party.
 - D. Heavy arrows indicate reporting through the President.
 - E. Thin arrows indicate reporting.

ADC ORGANIZATION - I

THIS CHART ILLUSTRATES THE TYPE OF ORGANIZATIONAL STRUCTURE USED BY AIR DEFENSE COMMAND. A TOTAL OF ELEVEN DIVISIONS AND EIGHT WINGS ARE ASSIGNED; HOWEVER, ONLY TWO TYPICAL DIVISIONS ARE SHOWN HERE DUE TO SPACE LIMITATIONS OF THE CHART.

PRIOR TO THE ADOPTION OF THIS TYPE ORGANIZATION IN FEBRUARY 1953, THE COMMAND HAD UNDERGONE A SERIES OF REORGANIZATIONS WITH THE LESSONS LEARNED BEING APPLIED HERE. BASICALLY, THESE LESSONS WERE:

A. THE DIVISION COMMANDER SHOULD HAVE CONTROL OF ALL ADC TOOLS IN HIS AREA WHICH ARE NECESSARY FOR ACTIVE AIR DEFENSE. THIS INCLUDES THOSE ADC BASES WHICH HAVE FIGHTER SQUADRONS THEREON.

B. ONE MAN ON EACH ADC OPERATED BASE SHOULD, WITH MINOR EXCEPTIONS, HAVE COMMAND OF ALL OF THE ADC UNITS LOCATED THEREON.

C. WINGS SHOULD BE INJECTED BETWEEN DIVISION AND OPERATING UNITS WHEN A REASONABLE SPAN OF CONTROL IS EXCEEDED. FOR OUR PURPOSE, THE MAXIMUM SPAN IS ABOUT 16 UNITS.

OPERATIONAL CONTROL OF THE FIGHTER AND AC&W UNITS IS EXERCISED DIRECTLY BY DIVISION, LEAVING THE WINGS AND AIR DEFENSE GROUPS RESPONSIBLE FOR ADMINISTRATION, TRAINING, AND SUPERVISION OF LOGISTICAL SUPPORT OF THEIR SUBORDINATE UNITS. THOSE FIGHTER SQUADRONS SHOWN AS BEING ASSIGNED DIRECT TO WING OR DIVISION ARE LOCATED UPON ANOTHER COMMAND'S BASE IN A TENANT STATUS. THE AIR DEFENSE GROUPS ARE THE OPERATING AGENTS FOR ADC-OWNED TACTICAL BASES. THIS GROUP ORGANIZATION IS ILLUSTRATED ON THE NEXT CHART.

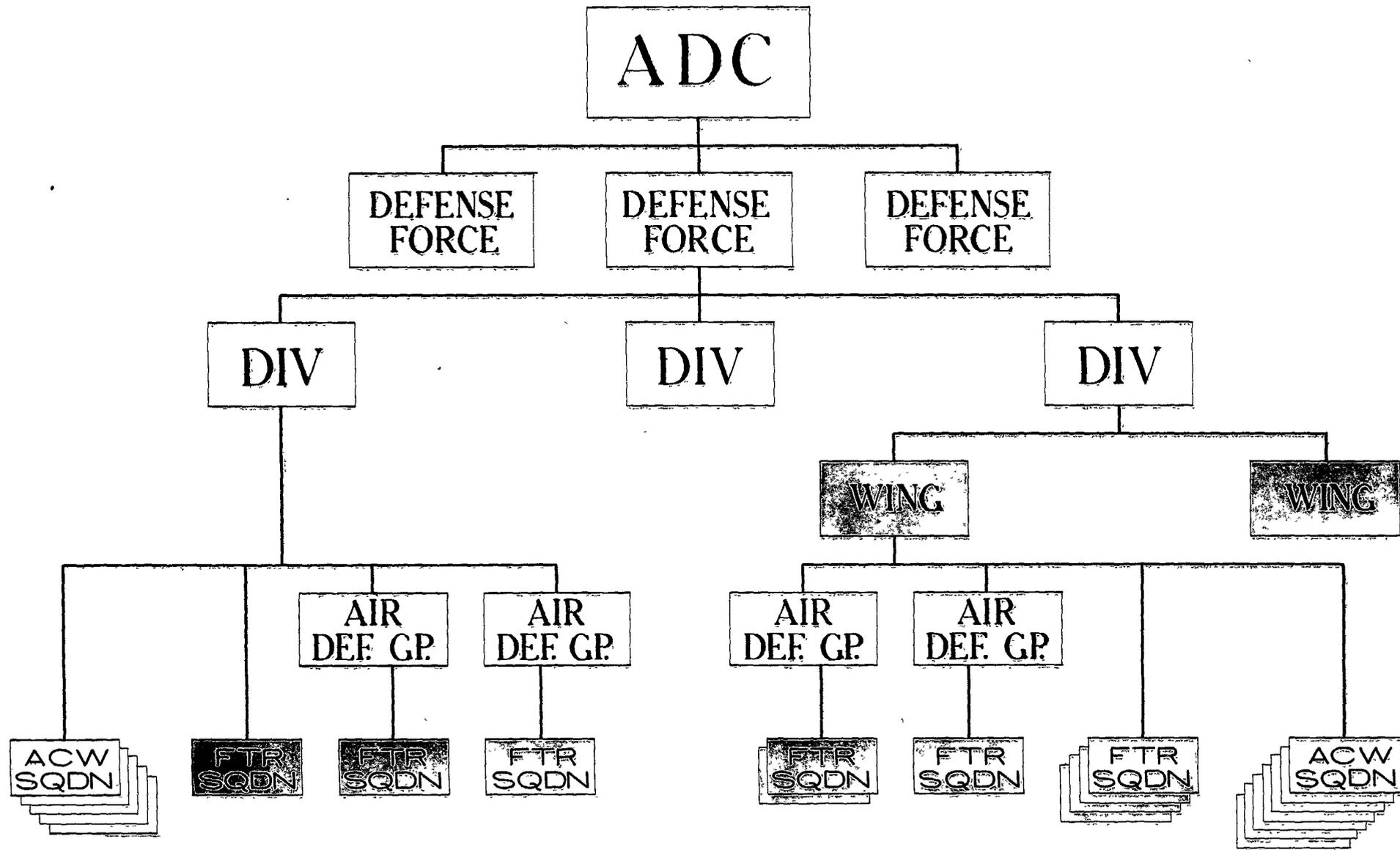

ADC ORGANIZATION II

SHOWN HERE IS THE ORGANIZATIONAL STRUCTURE OF AIR DEFENSE GROUPS WHICH OPERATE A MAJORITY OF OUR BASES. THIS IS A T/O UNIT WITH THE T/D AUGMENTATION VARYING WITH THE WORKLOAD. CERTAIN OF OUR LARGER BASES, SUCH AS HAMILTON, McCHORD, SELFRIDGE, ETC., ARE OPERATED BY A LARGER AIR DEFENSE GROUP -- IN THIS LARGER GROUP, THE FUNCTIONS OF AIR POLICE, FOOD SERVICE, MOTOR VEHICLE, ETC., ARE PERFORMED BY APPROPRIATE SQUADRONS RATHER THAN FLIGHTS AS SHOWN HERE.

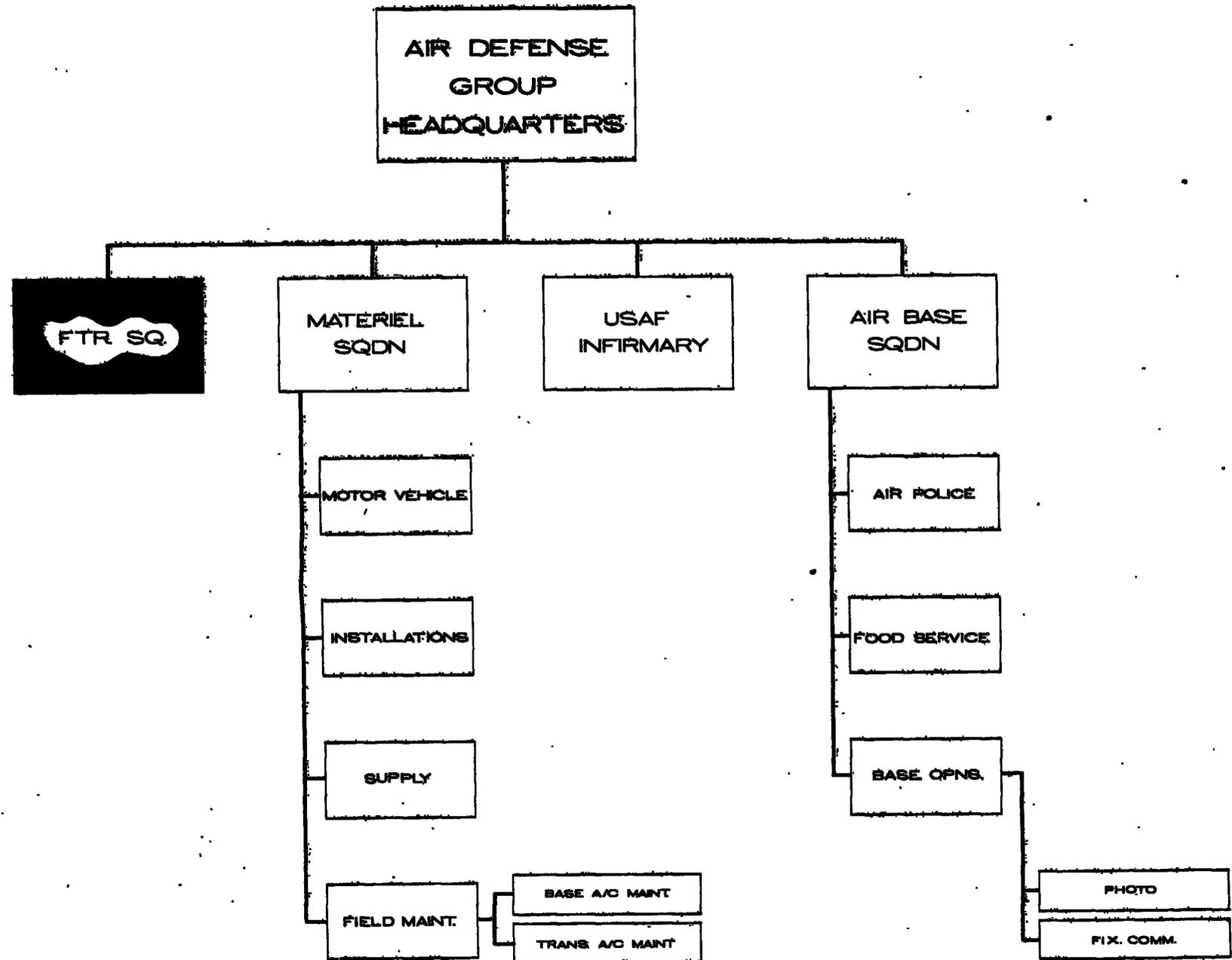

~~SECURITY INFORMATION~~~~SECRET~~VALUE OF WARNING

THE BASIC PREREQUISITE FOR THE EFFECTIVE PREPARATION AND CONDUCT OF AIR DEFENSE, AS IN ALL MILITARY OPERATIONS, IS THE AVAILABILITY OF TIMELY AND ACCURATE INTELLIGENCE.

GIVEN THIS INTELLIGENCE, THE EXPLOITATION OF THE INVALUABLE ELEMENT OF SURPRISE WILL BE DENIED THE ENEMY, STRATEGIC AIR COMMAND WILL NOT BE CAUGHT ON THE GROUND; - THE AIR DEFENSE FORCES WILL BE IN A MAXIMUM OPERATIONAL STATUS; - ESSENTIAL IDENTIFICATION PROCEDURES WOULD BE IN EFFECT; - AND CIVIL DEFENSE MEASURES CAN BE MORE READILY ACCOMPLISHED.

THIS CHART ILLUSTRATES THE BUILD-UP IN FIGHTER STRENGTH PER TIME OF WARNING. AFTER NORMAL DUTY HOURS, IT NOW TAKES AT LEAST ONE HOUR AND THIRTY MINUTES TO GET THE MAXIMUM ADC FORCE INTO ACTION. THIS IS MUCH TOO LONG AND IS DUE TO TRAINING REQUIREMENTS AND TO THE FACT THAT THE GREAT MAJORITY OF OUR CREWS AND KEY AIRMEN CANNOT OBTAIN FAMILY HOUSING ON OR NEAR THE BASE. MANY HAVE A 20 TO 40 MILE DRIVE TO MAKE. TO REQUIRE CREWS AND KEY AIRMEN TO REMAIN ON THE BASE IN SUFFICIENT NUMBERS TO MAN AND SERVICE THE FULL COMPLEMENT OF AIRCRAFT, ON A 24-HOUR BASIS, WOULD RESULT IN PRACTICALLY NO TIME WITH THEIR FAMILIES AND IS A QUESTIONABLE DEMAND IN PEACE TIME. TO CORRECT THIS SITUATION THERE IS CONTAINED IN THE AIR FORCE FISCAL 54 BUDGET REQUEST AN ITEM FOR MINIMUM ESSENTIAL HOUSING TO MEET THIS URGENT NEED.

ALSO INDICATED ON THE CHART IS AUGMENTATION FORCE BUILD-UP WITH INITIAL EMPLOYMENT IN PLACE AND THEN TIME FOR DEPLOYMENT. SIX HOURS IS AS YET SOMEWHAT OPTIMISTIC BUT WE ARE STRIVING TO PERFECT OUR PLANS TO ACHIEVE THIS GOAL.

THE IMPORTANCE OF ADVANCE WARNING THROUGH EFFECTIVE INTELLIGENCE OBVIOUSLY CANNOT BE OVER EMPHASIZED, BUT THE FACT REMAINS THAT AT THE PRESENT WE CANNOT DEPEND ON SUCH WARNING AND MUST PLAN FOR ONLY THAT WARNING GENERATED BY THE AIR DEFENSE SYSTEM ITSELF.

10

~~SECRET~~~~SECURITY INFORMATION~~

~~SECRET~~

VALUE OF WARNING

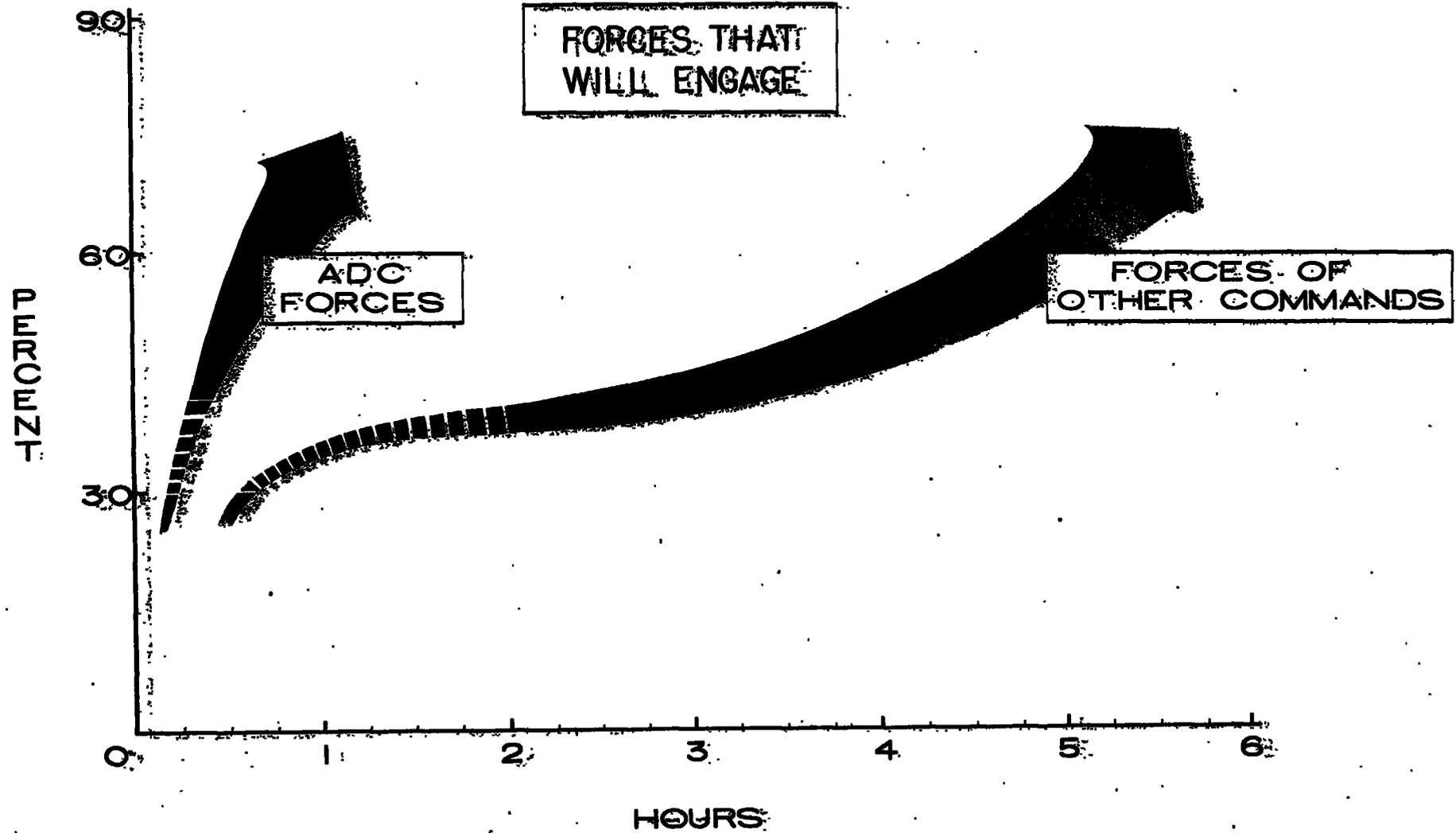

~~SECRET~~

~~SECURITY INFORMATION~~~~SECRET~~AIR DEFENSE PROGRAMS

HERE IS A COMPOSITE PICTURE OF FACILITIES PROGRAMMED, AND IN MOST CASES, FUNDED FOR. AN ESTABLISHMENT SUCH AS SHOWN ON THIS CHART WILL PROVIDE A RELATIVELY MODEST AIR DEFENSE OF THE UNITED STATES BY ABOUT 1955. THIS INCLUDES:

A PERMANENT U. S. RADAR NET OF 75 SITES AND 18 CONTROL CENTERS. (LIGHT SHADE)

A PERMANENT RADAR EXTENSION NET OF AT LEAST 33 SITES IN CANADA AND OTHER APPROACH AREAS,

A SEMI-MOBILE RADAR NET OF AT LEAST 79 SITES, PLUS SMALL LOW ALTITUDE GAP FILLERS. (VERY DARK SHADE - IN U. S.)

PICKET VESSELS ON AT LEAST 10 STATIONS.

AEW&C AIRCRAFT ON AT LEAST 8 STATIONS.

A GROUND OBSERVER CORPS OPERATING ON A 24 HOUR BASIS IN CRITICAL AREAS AND ON CRITICAL APPROACHES. SMALL AUTOMATIC RADARS MAY REPLACE ALL OR PART OF THE GOC IN THIS TIME PERIOD.

AN INTERCEPTOR FORCE OF AT LEAST 1125 AW INTERCEPTORS (57 SQUADRONS @ 25 PER SQUADRON).

ANTI-AIRCRAFT GUNS AND GUIDED ROCKETS FOR ADDITIONAL DEFENSE OF THE MOST CRITICAL TARGETS.

IN ADDITION TO THESE BASIC REQUIREMENTS, IMPROVEMENTS ARE PLANNED SUCH AS:

EQUIPMENT FOR AN IMPROVED SYSTEM OF THREAT EVALUATION AND WEAPON ASSIGNMENT.

IMPROVED INTERCEPTOR ARMAMENT TO INSURE "ONE-SHOT" DESTRUCTION.

AN EFFECTIVE IDENTIFICATION SYSTEM.

PASSIVE DETECTION AND ELECTRONIC COUNTERMEASURE EQUIPMENT.

A SECURE AIRCRAFT IFF IDENTIFICATION SYSTEM.

11

~~SECRET~~~~SECURITY INFORMATION~~

~~SECRET~~

GOAL OF PRESENT PROGRAMS

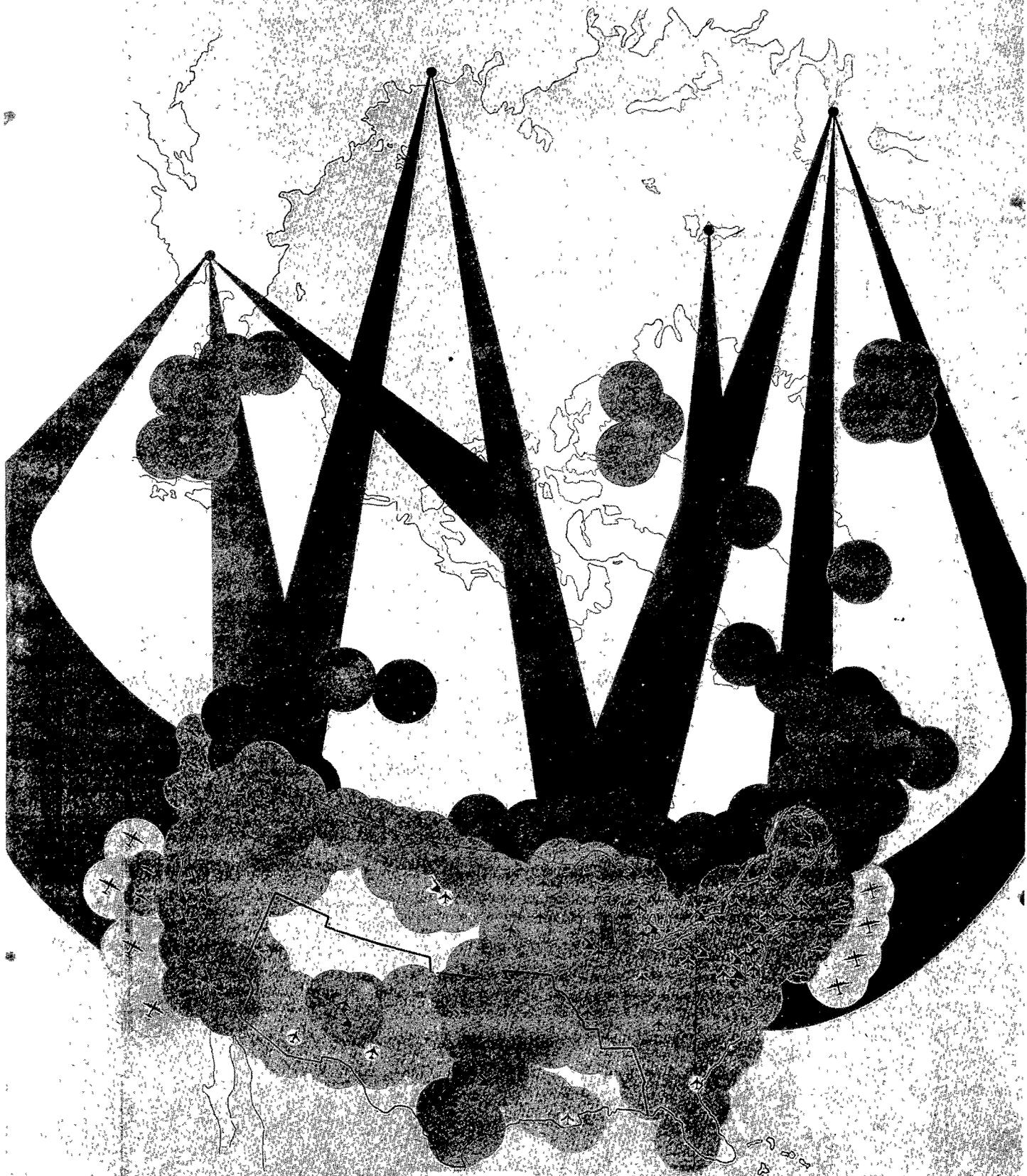

~~SECRET~~

THE FOUR BASIC ACTIONS

FUNDAMENTALLY, THE FOUR BASIC ACTIONS OF ANY AIR DEFENSE ARE: DETECTION, IDENTIFICATION, INTERCEPTION, AND DESTRUCTION. GIVEN ADEQUATE MEANS TO ACCOMPLISH THESE ACTIONS, EFFECTIVE AIR DEFENSE BECOMES A FUNCTION OF TIME. THE TIME REQUIRED FOR IDENTIFICATION, INTERCEPTION AND DESTRUCTION, MUST BE LESS THAN THE TIME BETWEEN INITIAL DETECTION UNTIL BOMB RELEASE LINE. ALL AIR DEFENSE COMMAND EFFORTS ARE DIRECTED TOWARD THE ULTIMATE IN THESE FUNCTIONS; THAT IS, THE RAPID, ACCURATE, ONE-SHOT DESTRUCTION OF HOSTILE AIRCRAFT AND MISSILES.

THE FIRST OF THESE ACTIONS -- DETECTION -- IS LOGICALLY ACCOMPLISHED BY THE RADAR DETECTION NET. IN THE CASE OF LOW FLYING AIRCRAFT, INITIAL DETECTION MAY BE MADE BY THE GROUND OBSERVER CORPS. INFORMATION ON AIRCRAFT DETECTED IS IMMEDIATELY FORWARDED TO THE AIR DEFENSE DIRECTION CENTERS WHERE IT IS ASSIGNED A TRACK NUMBER AND BECOMES A PART OF THE INFORMATION PROCESSED BY THE DIRECTION CENTER IN THE CONDUCT OF AIR DEFENSE.

NOW, THE PRESENT AND PROGRAMMED MEANS TO ACCOMPLISH EACH OF THESE FOUR BASIC ACTIONS WILL BE OUTLINED - FIRST, DETECTION.

DETECTION

IDENTIFICATION

INTERCEPTION

DESTRUCTION

THE FOUR BASIC ACTIONS

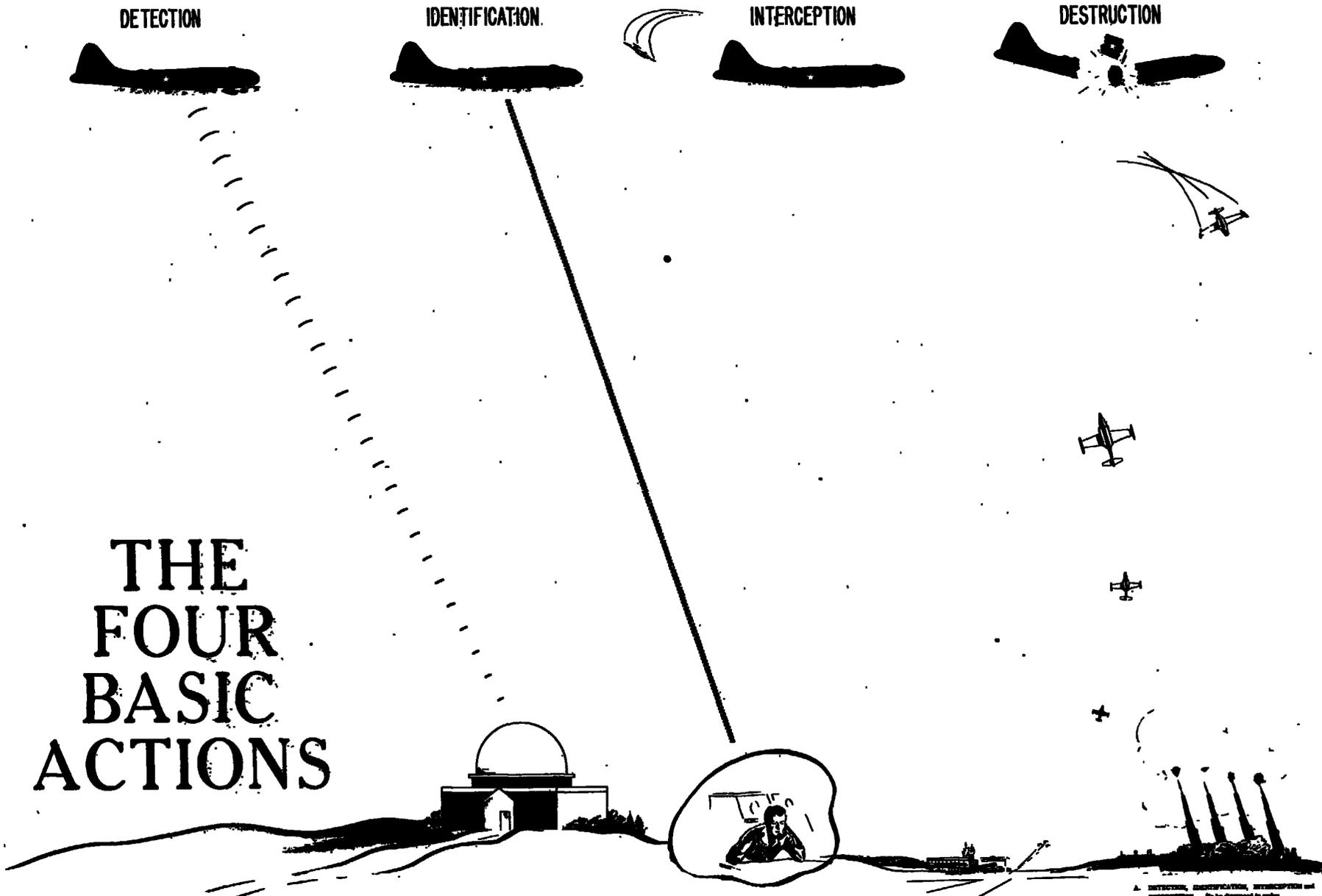

A. INTERCEPTION, IDENTIFICATION, INTERCEPTION and INTERCEPTION - To be discussed in order.

B. Air Defense system provided an interception on radar scope and controlled by system.

C. We depend upon detection by electronic or visual observation and subsequent tracking to depth by radar of identification. Detection scope includes early warning radar and radar and radar. Early warning radar.

~~SECURITY INFORMATION~~~~SECRET~~PERMANENT RADAR NET (THEORETICAL COVERAGE)

THE PERMANENT UNITED STATES RADAR NET CONSISTS OF SEVENTY-FIVE SITES AND ELEVEN AIR DEFENSE CONTROL CENTERS. DOTS INDICATE THE RADAR SITES, AND STARS, THE AIR DEFENSE CONTROL CENTERS. ALSO INDICATED IS THE THEORETICAL HIGH ALTITUDE COVERAGE.

THE DEPLOYMENT OF THESE RADARS WAS BASED UPON MANY FACTORS, INCLUDING LOCATION OF CRITICAL TARGETS, PROBABLE ENEMY ROUTES OF APPROACH, TERRAIN, ETC.

ALL OF THESE SITES ARE PRESENTLY OPERATING ON A 24-HOUR BASIS, BUT MANY DO NOT YET HAVE THEIR FULL COMPLEMENT OF EQUIPMENT.

13

~~SECRET~~~~SECURITY INFORMATION~~

~~SECURITY INFORMATION~~~~SECRET~~CALIBRATED RADAR

SUPERIMPOSED ON THE PREVIOUS CHART IS THE PRESENT CALIBRATED COVERAGE OF THE PERMANENT SITES. THE OUTER IRREGULAR LINE INDICATES COVERAGE AT 30,000 FEET AND THE INNER SHADED PORTION COVERAGE AT 5,000 FEET. THE DOTTED LINES INDICATE 30,000 FEET COVERAGE FROM TWO SEMI-MOBILE SITES NOW OPERATING.

FROM THIS, YOU CAN SEE THE APPROXIMATE ACTUAL RADAR COVERAGE THAT WE HAVE TODAY. NOTE THE LIMITED COVERAGE AT 5,000 FEET.

14

~~SECRET~~~~SECURITY INFORMATION~~

RADAR DEPLOYMENT

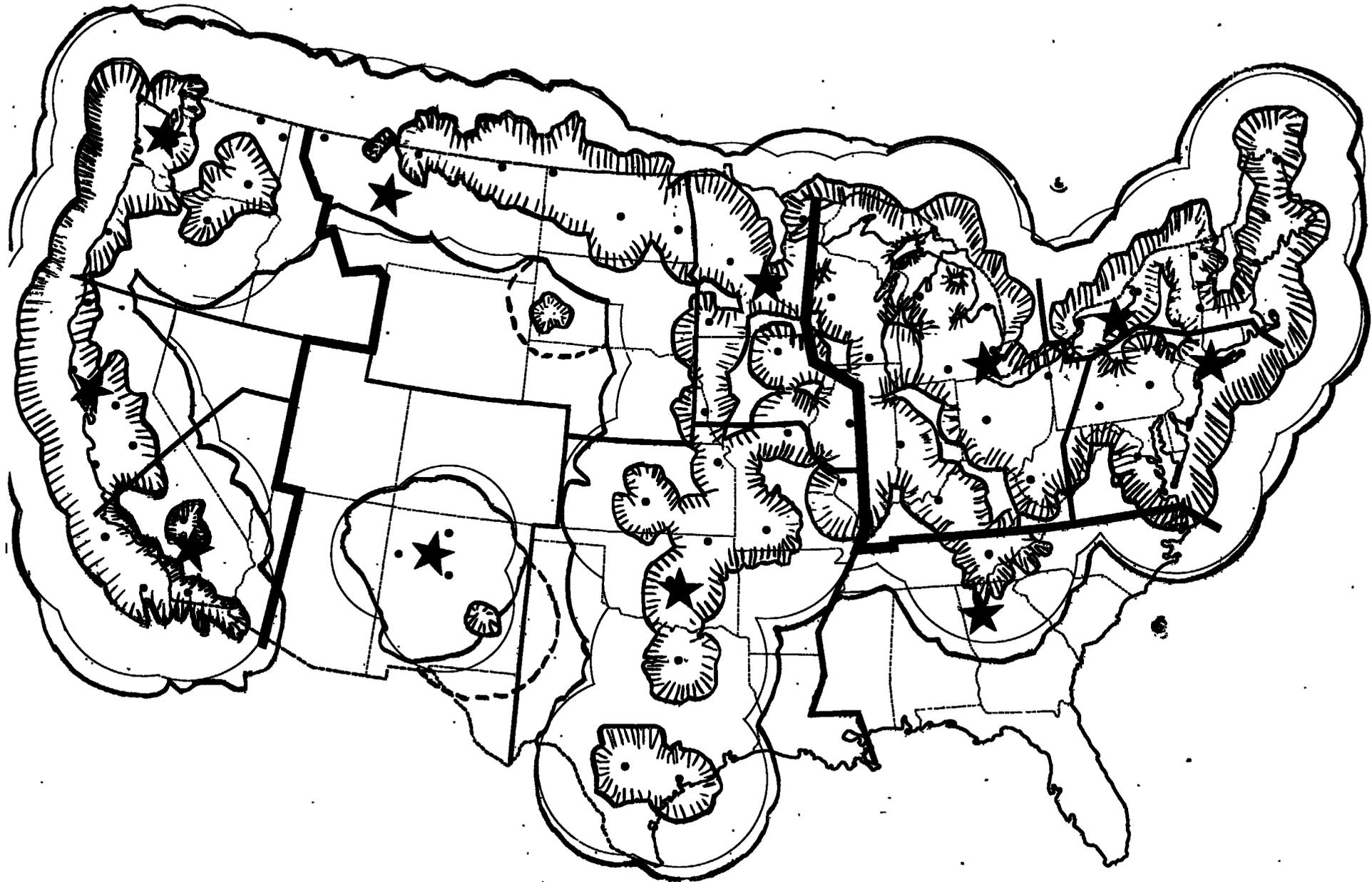

RADAR COVER LIMITATIONS

IN ORDER TO CLARIFY WHAT WE MEAN BY COVERAGE AT A SPECIFIED ALTITUDE, THIS CHART DEPICTS A VERTICAL CROSS-SECTION OF THE ROTATING COVERAGE PATTERN OF TWO RADARS BASED 190 MILES APART. THIS IS TYPICAL OF OUR PERMANENT RADAR NET. THIS DRAWING IS NOT TO SCALE, BUT DESIGNED TO ILLUSTRATE THE LOW ALTITUDE GAP WHICH RESULTS FROM RADAR IMPULSES, IN THE LOWER LIMIT, BEING CONFINED TANGENT TO THE EARTH'S SURFACE RATHER THAN THE DESIRED FEATURE OF FOLLOWING THE CURVATURE OF THE EARTH. OBSTRUCTIONS SUCH AS MOUNTAINS FURTHER INCREASE THE DEAD SPACE. AN OBVIOUS SOLUTION IS, OF COURSE, MORE RADARS, BUT LARGE NUMBERS WOULD BE REQUIRED AND THE PRICE OF PRESENT TYPE RADARS WOULD MAKE THE COST PROHIBITIVE.

RADAR COVERAGE LIMITATIONS

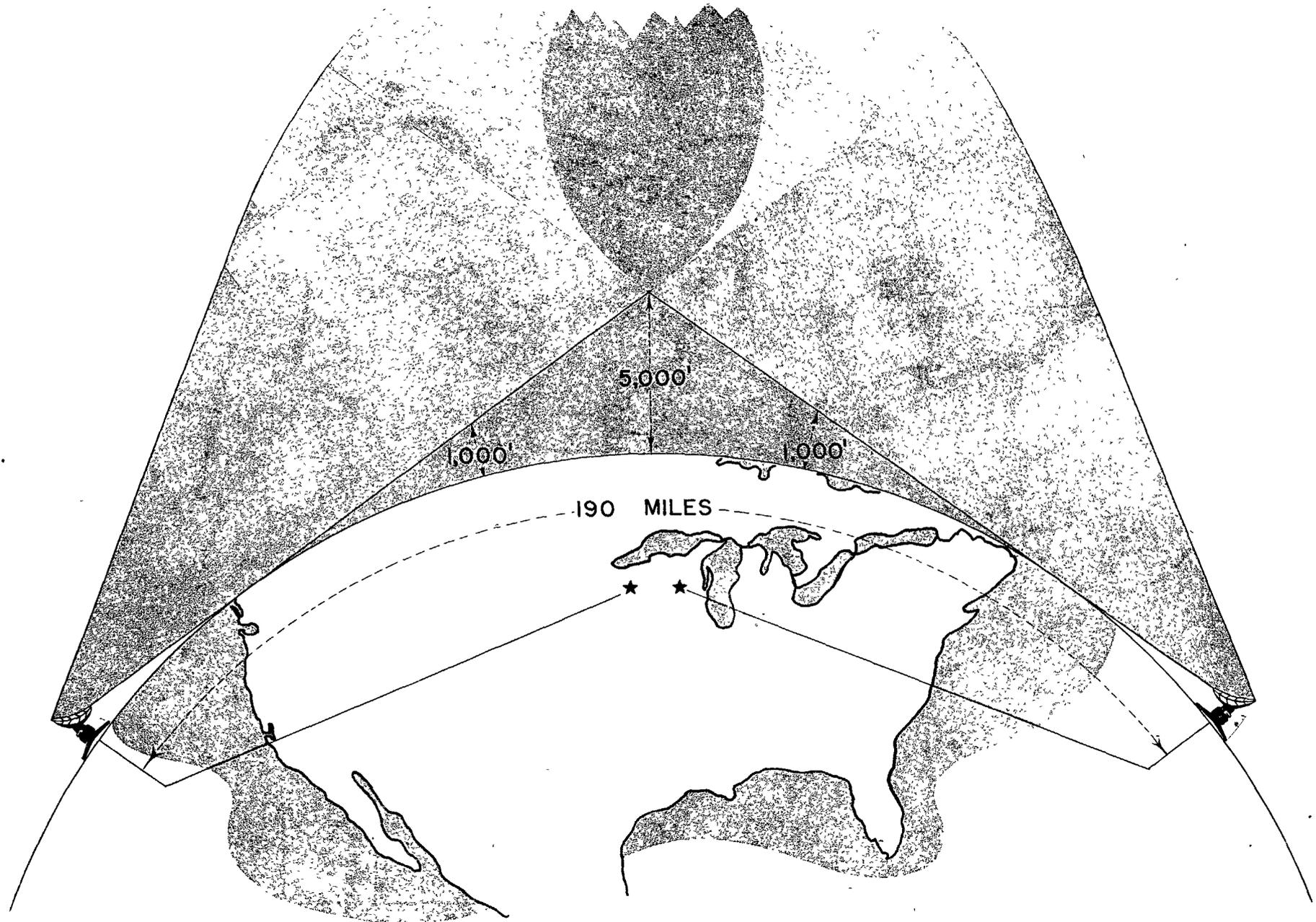

~~SECURITY INFORMATION~~~~RESTRICTED~~AC&W STATION

THIS SHOWS A TYPICAL ISOLATED RADAR SITE. THE ONE DEPICTED HERE IS AN AIR DEFENSE DIRECTION CENTER WITH CPS-6 RADAR. TO KEEP THIS TYPE SITE OPERATING AT A 24 HOUR/DAY RATE FOR SURVEILLANCE AND FIGHTER CONTROL REQUIRES ABOUT 42 OFFICERS AND 345 AIRMEN.

THIS TYPE SITE COSTS ABOUT \$5,000,000 COMPLETE, DEPENDING UPON LOCATION.

16

~~RESTRICTED~~~~SECURITY INFORMATION~~

AIRCRAFT CONTROL & WARNING STATION

DESCRIPTION:

- RADIO STATION
- GATE HOUSE
- FAMILY HOUSING AREA
- POWER SUPPLY
- BOQ.
- OPERATIONS
- ADMINISTRATION
- POST EXCHANGE
- MESS HALL
- RADAR TOWER
- RECREATION
- BKS. & NCO. BQ. AREA
- MOTOR REPAIR SHOP
- MAINTENANCE
- CENTRAL HEATING PLANT

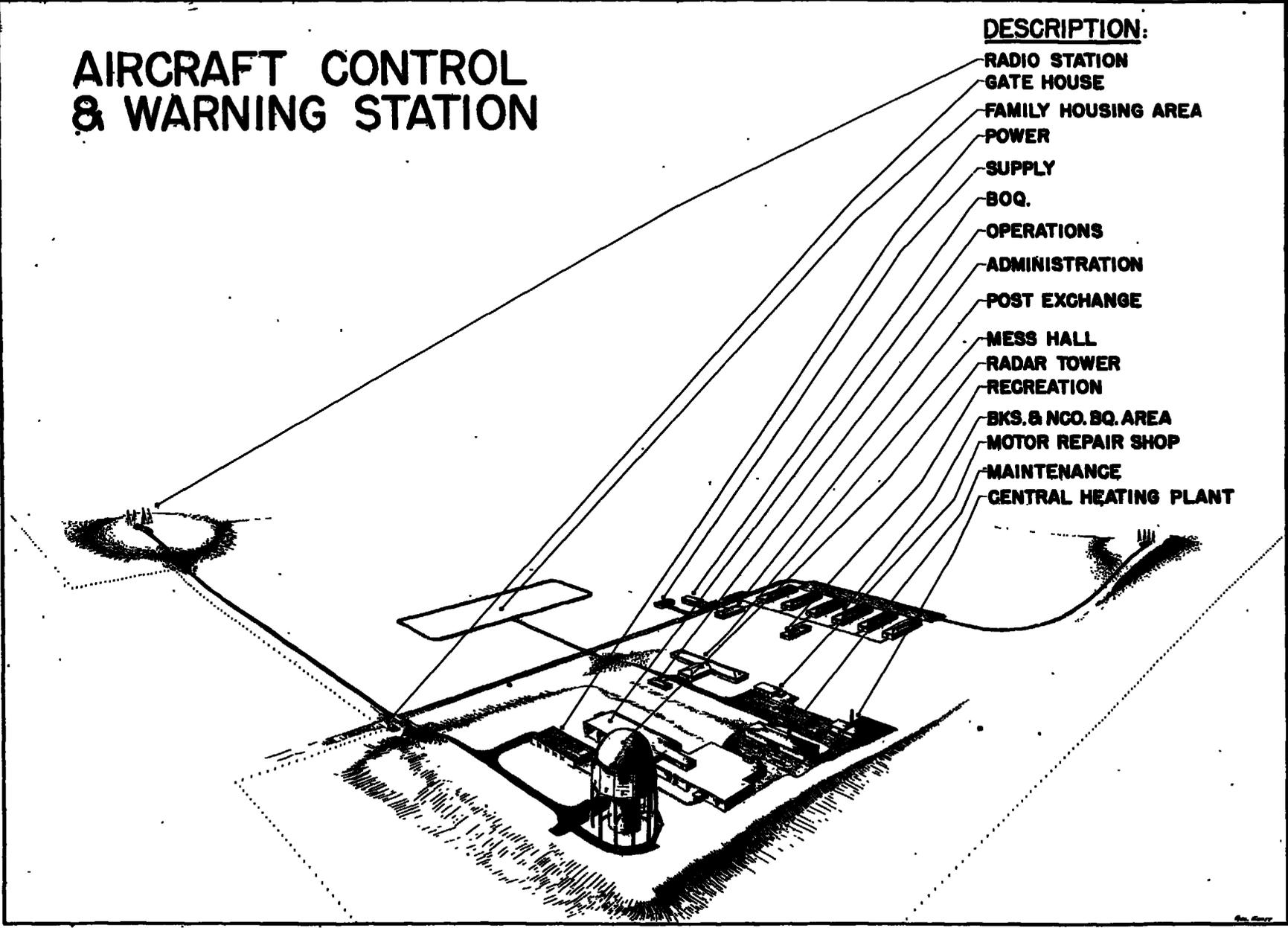

~~SECURITY INFORMATION~~~~SECRET~~RADAR EXTENSION PROGRAM

SHOWN ON THIS CHART IS THE THEORETICAL COVERAGE OF THE PROGRAMMED CANADIAN AND NORTHEAST AIR COMMAND RADAR NETS. THESE SEPARATE RADAR NETS ARE CLOSELY COORDINATED WITH THE U. S. RADAR NET AND, IN EFFECT, SERVE AS AN EXTENSION OF THE U. S. NETWORK.

THE LARGE CIRCLES INDICATE THE SITES WHICH WILL BE MANNED INITIALLY BY U. S. PERSONNEL.

THE DOTS INDICATE PRESENTLY OPERATING AND PROGRAMMED CANADIAN SITES.

THE TARGET DATE FOR HAVING ALL SITES TECHNICALLY EQUIPPED WAS 1 JULY OF LAST YEAR. AS OF THAT DATE, ALL THE RADAR GEAR WAS SUPPOSED TO HAVE BEEN IN PLACE AND CAPABLE OF OPERATION. IT IS NOW APPARENT THAT THIS PROGRAM WILL BE ABOUT TWO YEARS BEHIND SCHEDULE, DUE PRIMARILY TO EQUIPMENT PRODUCTION DELAYS. THE DELAY IN THE ACTIVATION OF THESE SITES IS ALSO BEING AGGRAVATED BY TREMENDOUS LOGISTIC COMMUNICATIONS AND JUST PLAIN LIVING PROBLEMS INVOLVED IN ESTABLISHING AND OPERATING RADAR SITES IN THE REMOTE NORTHERN REGIONS INDICATED.

~~SECRET~~~~SECURITY INFORMATION~~

RADAR EXTENSION PROGRAM

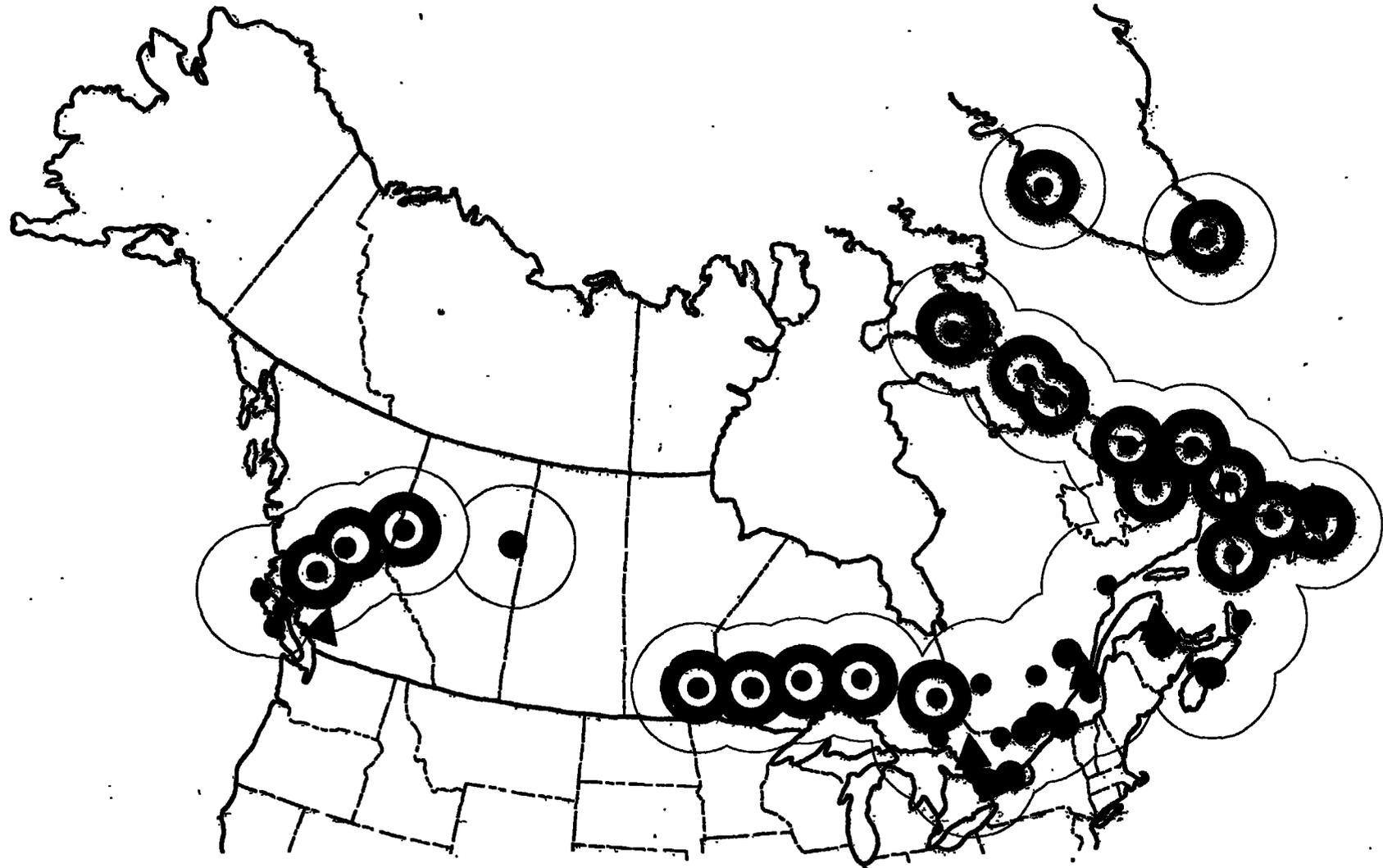

~~SECURITY INFORMATION~~~~RESTRICTED~~DOUBLE PERIMETER AIR DEFENSE

IN CONTINUOUS STUDIES TOWARD IMPROVING THE AIR DEFENSE SYSTEM, CONSIDERATION IS GIVEN TO EVALUATION OF DAY-TO-DAY OPERATIONAL STATISTICS AND RESULTS OF AIR DEFENSE MANEUVERS. ALSO TAKEN INTO CONSIDERATION ARE REPORTS BY SCIENTIFIC STUDY GROUPS, SUCH AS THE WEAPONS SYSTEMS EVALUATION GROUP, THE RAND CORPORATION, AND PROJECT CHARLES AND LINCOLN. AS A RESULT, THE THEORY OF DOUBLE PERIMETER AIR DEFENSE HAS BEEN DEVELOPED. AN ACTIVE AIR DEFENSE BAND OF AT LEAST 250 MILES IN DEPTH IS ESTABLISHED AROUND THE CRITICAL TARGET AREA. THE FUNCTIONS OF DETECTION, IDENTIFICATION, INTERCEPTION, AND DESTRUCTION ARE CARRIED OUT IN THIS BAND. TO ATTAIN THIS CAPABILITY, A DOUBLE PERIMETER OF PRIME RADARS, WITH SATELLITE GAP FILLERS, IS ESTABLISHED. THE INNER PERIMETER IS 70 MILES OUTSIDE OF THE TARGET AREA. THE NEXT PERIMETER IS ANOTHER 120 MILES FARTHER OUT. INTERCEPTORS ARE LOCATED IN THIS BAND FOR IMMEDIATE EMPLOYMENT. AIR TRAFFIC CORRIDORS WITH SECURITY REPORTING POINTS ARE ESTABLISHED THROUGH THE BAND.

THE DOUBLE PERIMETER DEFENSE DOES NOT ELIMINATE DEFENSE IN DEPTH THROUGHOUT THE TARGET AREAS - RATHER IT IS THE INITIAL "MAIN LINE OF RESISTANCE."

FOR DETECTION OF HIGH ALTITUDE ATTACKS, THE DISTANCE BETWEEN RADAR SITES MAY BE SUBSTANTIAL - (150 to 250 MILES). FOR COVERAGE DOWN TO 5,000 FEET, A SPACING OF 120 MILES BETWEEN SITES ON EACH PERIMETER IS ACCEPTABLE. FOR COVERAGE OF ALTITUDES BELOW 5,000 FEET, A REQUIREMENT EXISTS FOR THE DEPLOYMENT OF SMALL RADARS FOR GAP FILLING WITH THEIR INTELLIGENCE REMOTED TO THE PRIME RADAR SITES.

18

~~RESTRICTED~~~~SECURITY INFORMATION~~

~~RESTRICTED - SECURITY INFORMATION~~

AIR DEFENSE COMMAND

THEORY OF DOUBLE PERIMETER DEFENSE**REQUIREMENTS**

 DOUBLE PERIMETER OF PRIME RADARS, 120 MI BETWEEN PERIMETERS AND 120 MI BETWEEN STATIONS ON EACH PERIMETER.

 SMALL UNMANNED RADARS REMOTED TO PRIME RADARS FOR LOW ALTITUDE COVERAGE (BELOW 5,000')

 FIGHTER SQUADRONS, DEPLOYED IN PERIMETER ZONE AND IN TARGET AREA

24 HOUR GOC IN PERIMETER AREA

ADIZ IN PERIMETER AREA (ALL ALTITUDES)

 TRAFFIC CONTROL CORRIDORS THROUGH PERIMETER AREA

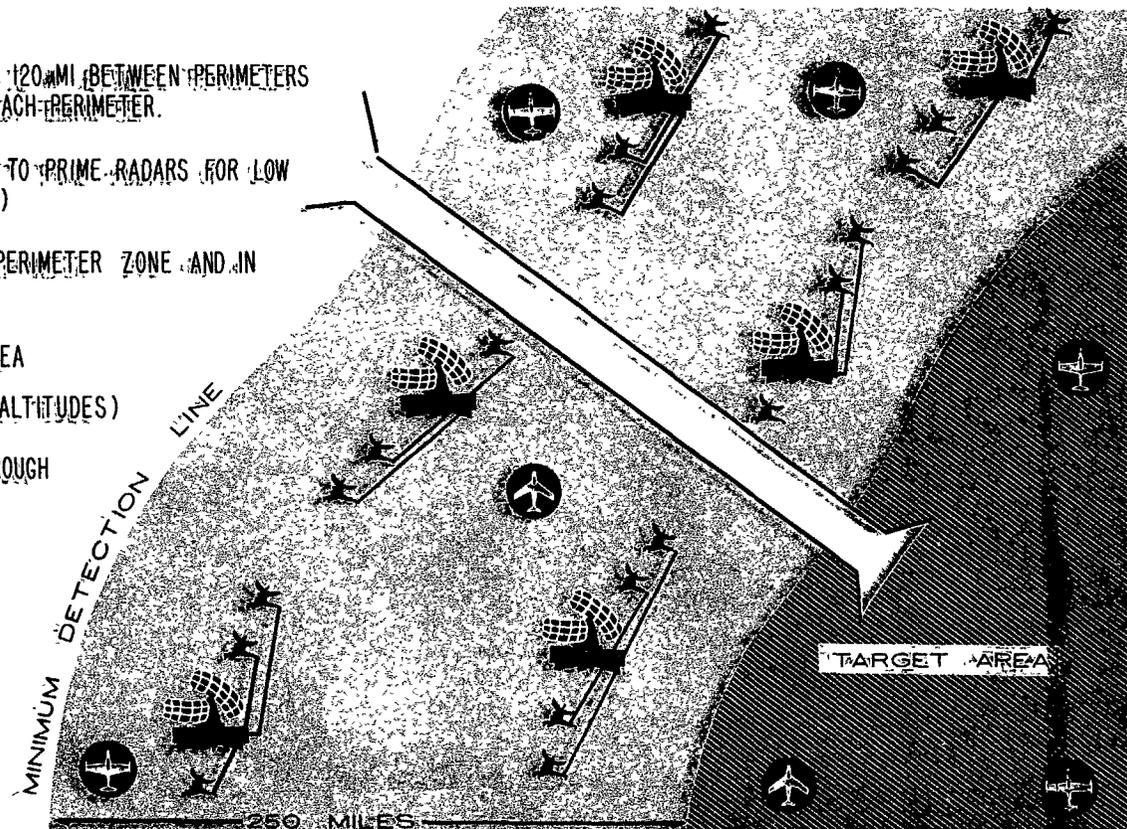
~~RESTRICTED - SECURITY INFORMATION~~

~~SECURITY INFORMATION~~**SECRET**PERMANENT AND FIRST PHASE MOBILE RADAR

AS INTELLIGENCE SOURCES INDICATED THE INCREASING CAPABILITY OF THE ENEMY TO PENETRATE AND ATTACK AT LOW ALTITUDES THE LOW ALTITUDE GAPS IN THE PERMANENT RADAR NET, AS CONFIRMED BY ACTUAL CALIBRATION, CONSTITUTED A SERIOUS DEFICIENCY IN THE SYSTEM. THIS DEFICIENCY NECESSITATED REPROGRAMMING THE PROPOSED RADAR NET TO ELIMINATE THESE GAPS BY REPOSITIONING PROGRAMMED SITES AND INSTALLATIONS OF ADDITIONAL RADARS.

SHOWN ON THIS CHART ARE THE PERMANENT SITES (SOLID BLACK CIRCLES), THE PROGRAMMED CANADIAN SITES (HOLLOW CIRCLES), AND THE PROGRAMMED FIRST PHASE SEMI-MOBILE SUPPLEMENTARY SITES (HATCHED CIRCLES). THESE CIRCLES ARE SCALED TO INDICATE THEORETICAL COVERAGE AT 5,000 FEET. ONCE AGAIN, ALL THESE SITES ARE NOT YET IN EXISTENCE NOR WILL THE ACTUAL COVERAGE BE AS COMPLETE AS INDICATED AT THIS ALTITUDE.

THIS PROGRAM WILL PROVIDE THE INITIAL STEP FOR COVERAGE OF THE MOST IMPORTANT STRATEGIC AIR COMMAND BASES; AND AS SHOWN BY THE SOLID BLACK LINE, THE PARTIAL ACCOMPLISHMENT OF A SYSTEM OF DOUBLE AIR DEFENSE PERIMETERS AROUND THE NORTHEAST, NORTHWEST, AND WEST COAST TARGET AREAS. SOME OF THESE SITES WILL BE OPERATING THIS SUMMER AND THE MAJORITY SHOULD BE COMPLETED BY SPRING OF 1954.

AS YOU CAN SEE BY THE BROKEN LINES, A REQUIREMENT EXISTS FOR MORE RADARS TO COMPLETE THE PERIMETERS. NOTE PARTICULARLY THAT VITAL COASTAL PERIMETERS MUST BE PROVIDED RADAR SURVEILLANCE THROUGH THE PLANNED USE OF PICKET VESSELS AND AIRBORNE EARLY WARNING AND CONTROL AIRCRAFT.

SECRET~~SECURITY INFORMATION~~

SECRET

1ST PHASE MOBILE PROGRAM

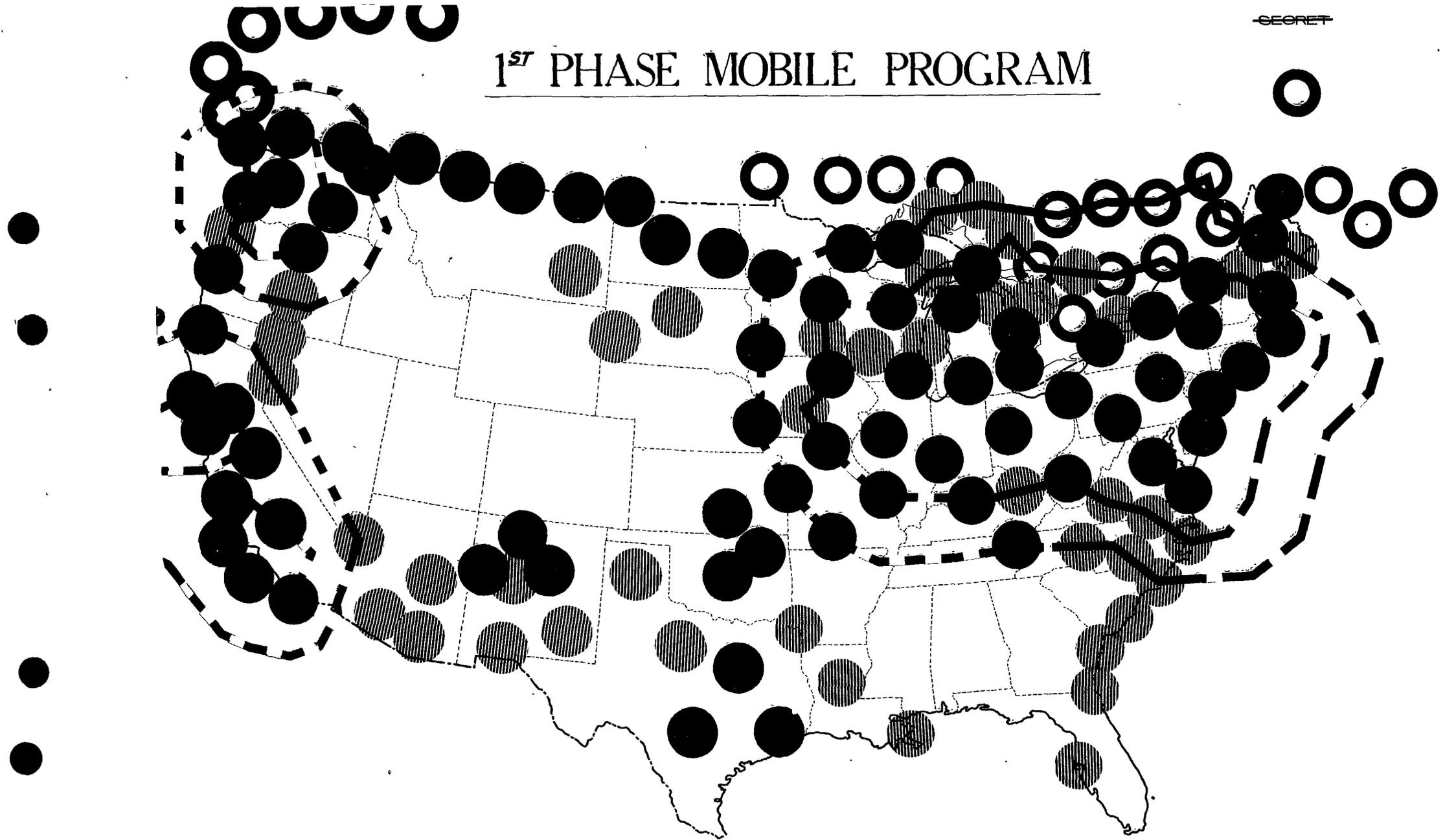

~~SECURITY INFORMATION~~**SECRET**SECOND PHASE MOBILE RADAR PROGRAM

THE WAVY HATCHED CIRCLES INDICATE PROGRAMMED POSITIONS ON THE 35 SECOND PHASE MOBILE RADAR SITES. THESE SITES ARE POSITIONED IN A MANNER WHICH INCREASES THE SURVEILLANCE WITHIN THE DOUBLE PERIMETERS PROTECTING THE CRITICAL INDUSTRIAL AREAS. THIS PROGRAM HAS BEEN APPROVED BY HEADQUARTERS USAF AND WILL BE IMPLEMENTED AS SOON AS FUNDS, EQUIPMENT AND PERSONNEL BECOME AVAILABLE.

THESE CIRCLES ARE ALSO SCALED TO INDICATE THEORETICAL COVERAGE AT 10,000 FEET.

ALTHOUGH THIS WOULD GREATLY IMPROVE THE EXISTING RADAR SURVEILLANCE AND SERVE TO FURTHER CLOSE THE LOW ALTITUDE GAPS, MANY GAPS ARE STILL IN EXISTENCE THROUGHOUT THE DOUBLE PERIMETERS AND ACROSS VITAL APPROACH ROUTES.

DEVELOPMENT IS BEING VIGOROUSLY PURSUED TOWARDS SOLVING THE LOW ALTITUDE APPROACH DETECTION PROBLEM EMPLOYING A RELATIVELY CHEAP SMALL AUTOMATIC RADAR CAPABLE OF PROVIDING SURVEILLANCE FROM THE SURFACE TO 6,000 FEET FOR DISTANCES OF 30 MILES.

20

SECRET~~SECURITY INFORMATION~~

SECRET

2ND PHASE MOBILE PROGRAM

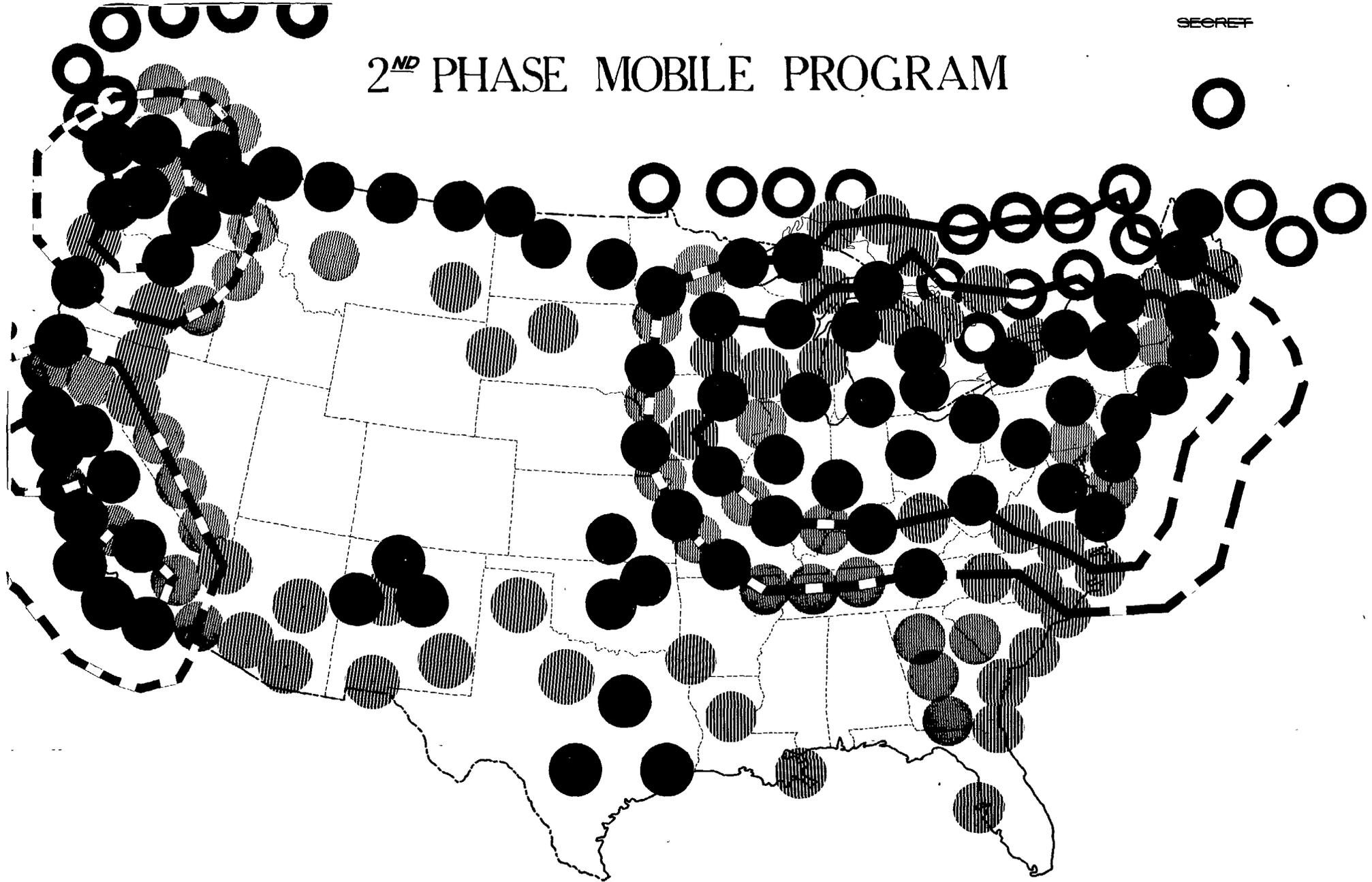

~~SECRET~~

~~SECURITY INFORMATION~~**SECRET**GAP FILLER RADAR

THE SMALL DOTS INDICATE THE INITIAL PLANNED POSITIONS OF THE LOW ALTITUDE AUTOMATIC GAP FILLER TYPE RADARS. SOLID BLACK IN U. S. - HATCHED IN CANADA. APPROXIMATELY 300 WILL BE REQUIRED TO PROVIDE THE DESIRED LOW ALTITUDE SURVEILLANCE. THIS PROGRAM WILL BE IMPLEMENTED AS SOON AS SERVICE TESTS CAN BE CONDUCTED ON SEVERAL DIFFERENT RADAR SETS UNDER CONSIDERATION. UNTIL SUCH TIME AS WE HAVE SUCH RADAR DEVELOPED, INSTALLED AND OPERATING, THE ONLY PRESENT LOW ALTITUDE DETECTION MEANS AVAILABLE IS THE GROUND OBSERVER CORPS.

21

SECRET~~SECURITY INFORMATION~~

SECRET

GAP FILLER PROGRAM

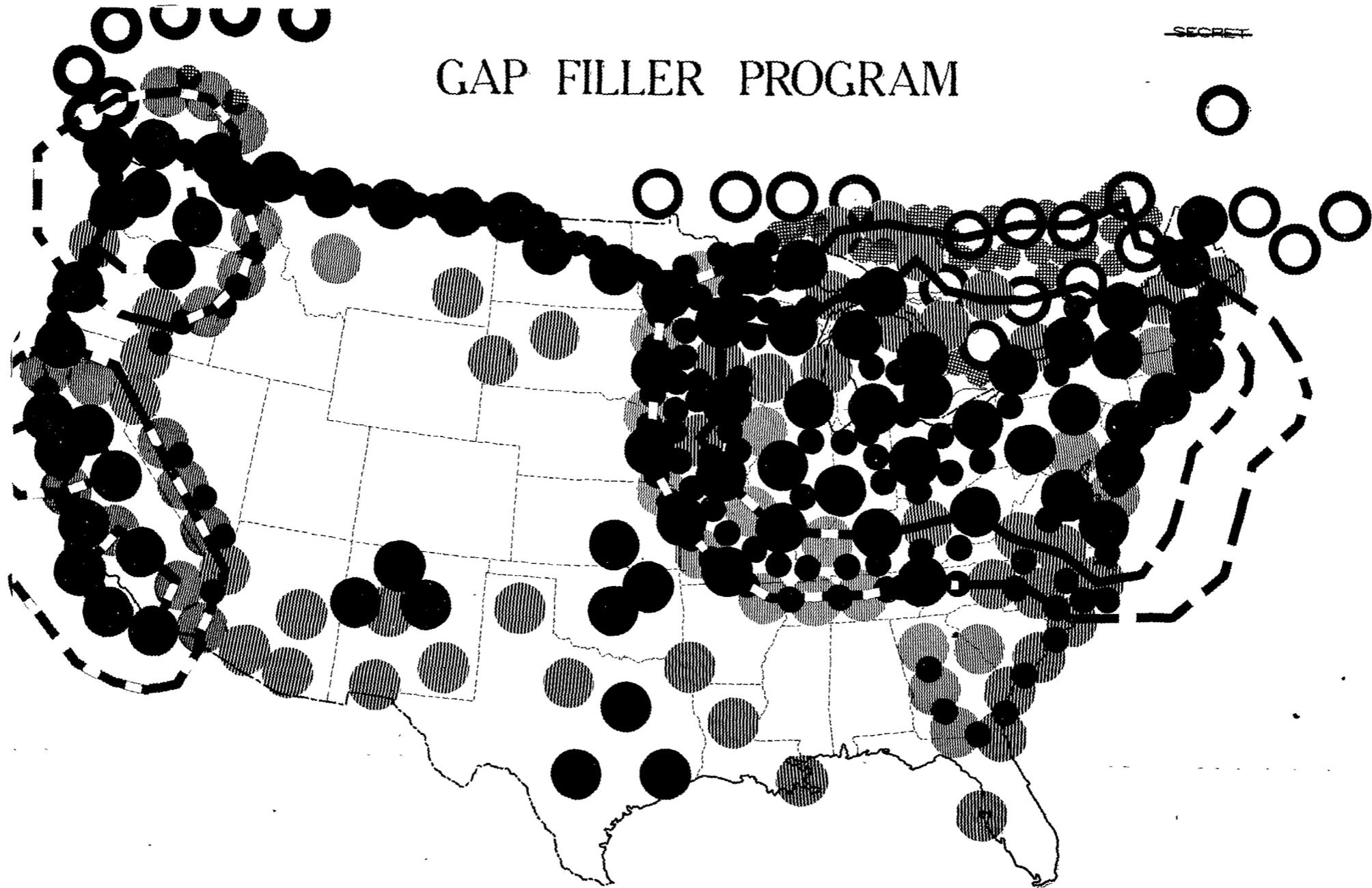

SECRET

GROUND OBSERVER SYSTEM

AN INTEGRAL PART OF THE EXISTING DETECTION NET IS THE GROUND OBSERVER CORPS. THIS SYSTEM DEPENDS UPON CIVILIAN VOLUNTEERS AND IS THE ONLY MEANS NOW AVAILABLE FOR DETECTION OF LOW FLYING AIRCRAFT. ITS EFFICIENCY IN THIS MISSION IS IN DIRECT PROPORTION TO THE MANNING ACHIEVED, THE SPIRIT AND ENTHUSIASM OF THE VOLUNTEERS, AND THE CONTINUAL TRAINING EFFORT GIVEN BY THE AIR FORCE.

THE SYSTEM IS ORGANIZED INTO 49 AREAS, EACH CONTAINING A FILTER CENTER. THE FILTER CENTERS ARE INDICATED BY DOTS. EACH IS STAFFED WITH A SMALL PERMANENT AIR FORCE DETACHMENT OF OFFICERS AND AIRMEN. THEY HAVE THE DUAL MISSION OF TRAINING THE 500 TO 1000 VOLUNTEERS TO OPERATE THE FILTER CENTER AND THE MANY VOLUNTEERS WHO SUPERVISE THE MANNING OF THE OBSERVATION POSTS WITHIN THE AREA.

TO REACH THE DESIRED EFFECTIVENESS, SOME 19,000 OBSERVER POSTS AND A MINIMUM OF HALF MILLION VOLUNTEERS ARE REQUIRED. ONLY ABOUT 30% OF THE REQUIRED VOLUNTEERS ARE NOW ACTIVELY PARTICIPATING. AS THE FULL EFFECT OF THE EDUCATION AND RECRUITING PROGRAMS NOW BEING LAUNCHED IS FELT, THIS PERCENTAGE SHOULD INCREASE SUBSTANTIALLY.

THE DARKER SHADED PORTION IS THE AREA IN WHICH THE SYSTEM HAS BEEN ON CONTINUOUS 24-HOUR DUTY SINCE JULY LAST. THE REQUIREMENT FOR THIS 24-HOUR WATCH WILL CONTINUE UNTIL A MECHANICAL OR ELECTRONIC DEVICE IS ACTUALLY AVAILABLE AND HAS PROVED IT CAN REPLACE THE EYES AND EARS OF THE HUMAN OBSERVER.

GROUND OBSERVER CORPS

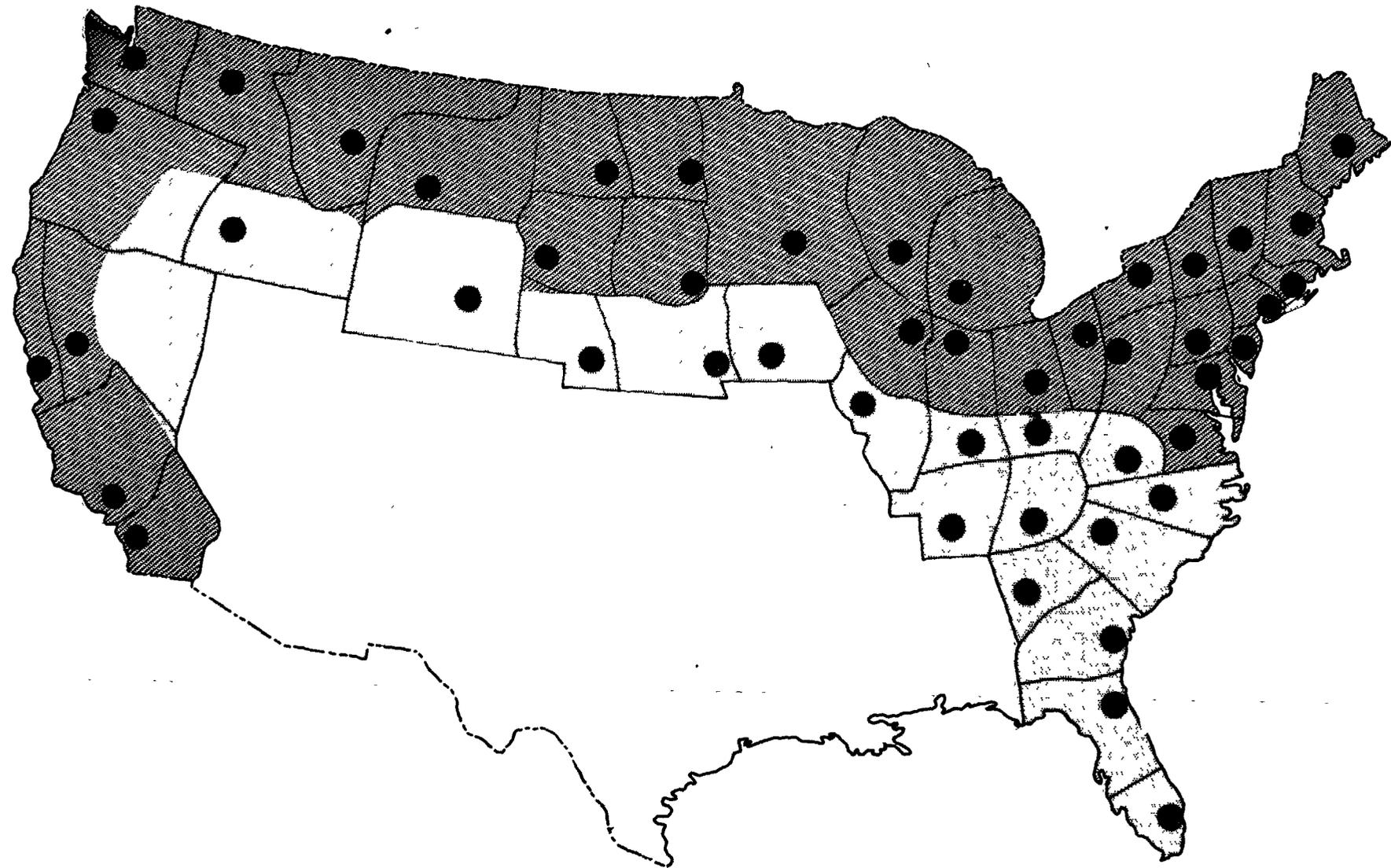

ORGANIZATION

THE GOC IS PRESENTLY OPERATED AS A VOLUNTEER AUXILIARY TO THE AIR FORCE. HERE IS THE PRESENT ORGANIZATION. NOTE THAT THE FILTER CENTER IS THE ONLY PLACE IN THE SYSTEM WHERE WE HAVE ACTUAL INTEGRATED MILITARY-CIVILIAN EMPLOYMENT DURING ACTUAL OPERATION. THE ORGANIZATION REQUIREMENT FOR AN AREA IS ESTABLISHED BY THE AIR FORCE; THE STATES ARE THEN RESPONSIBLE FOR THE RECRUITING AND PERSONNEL ADMINISTRATION OF THE VOLUNTEERS. THE AIR FORCE THEN TRAINS THE VOLUNTEERS AND HAS OPERATIONAL CONTROL OVER THE SYSTEM.

GROUND OBSERVER CORPS

MILITARY & CIVILIAN ORGANIZATION

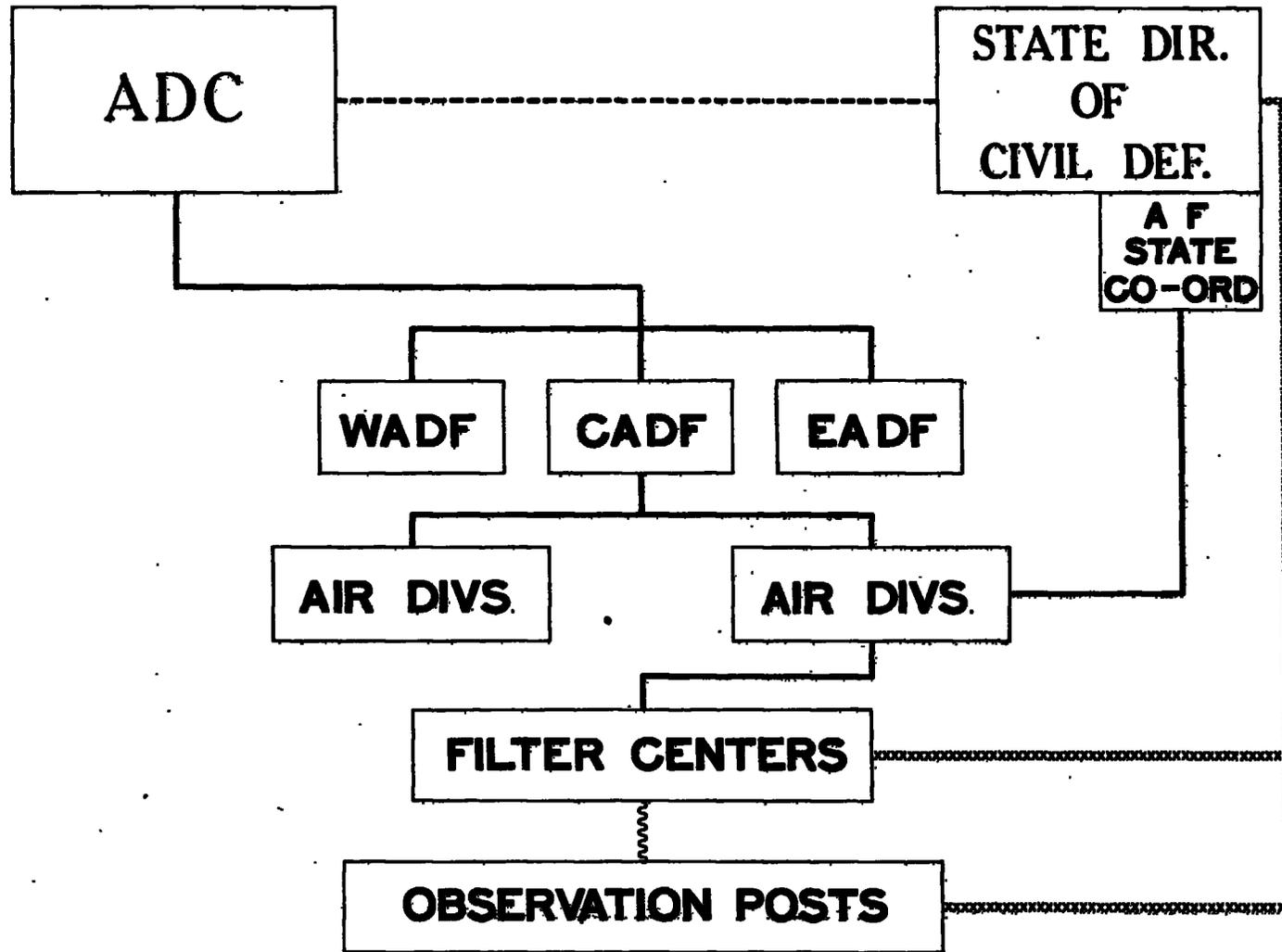

~~SECURITY INFORMATION~~~~RESTRICTED~~PICKET SHIPS

COASTAL TARGETS SUCH AS NEW YORK ARE INDEFENSIBLE IF WE DEPEND SOLELY UPON A LAND BASED RADAR SYSTEM. WE MUST EXTEND RADAR COVERAGE SEAWARD IN ORDER TO PROVIDE TIME FOR IDENTIFICATION, INTERCEPTION AND DESTRUCTION OF HOSTILE AIRCRAFT BEFORE THEY REACH THE BOMB RELEASE LINE. THIS SEAWARD EXTENSION OF RADAR COVERAGE IS ALSO A REQUIREMENT FOR COMPLETING THE DOUBLE PERIMETERS AROUND CRITICAL AREAS. PICKET SHIPS, STRATEGICALLY LOCATED, WOULD NOT ONLY SERVE TO EXTEND RADAR COVERAGE SEAWARD AS AN EARLY WARNING DEVICE BUT WOULD, IN ADDITION, SERVE AS A MEANS OF CONTROLLING FIGHTERS AND PROVIDING CORRIDOR POINTS FOR INBOUND AND OUTBOUND AIR TRAFFIC.

SHOWN ON THIS CHART IS A PROPOSED PICKET SHIP DISPOSITION, BASED ON REQUIRED HIGH ALTITUDE COVERAGE AS EXTENDED IN VERY DARK SHADE. THE LINED AREA INDICATES THE INCREASE IN THE MAXIMUM POSSIBLE COMBAT AREA AGAINST HIGH ALTITUDE ATTACK. MORE VITAL IS THE GAIN OF CRITICAL TIME BY PICKET SHIP RADAR DETECTION OF LOW ALTITUDE APPROACHES. PICKET SHIPS ARE AT PRESENT ONE OF OUR MOST URGENT REQUIREMENTS.

24

~~RESTRICTED~~~~SECURITY INFORMATION~~

~~SECRET~~

PICKET SHIPS

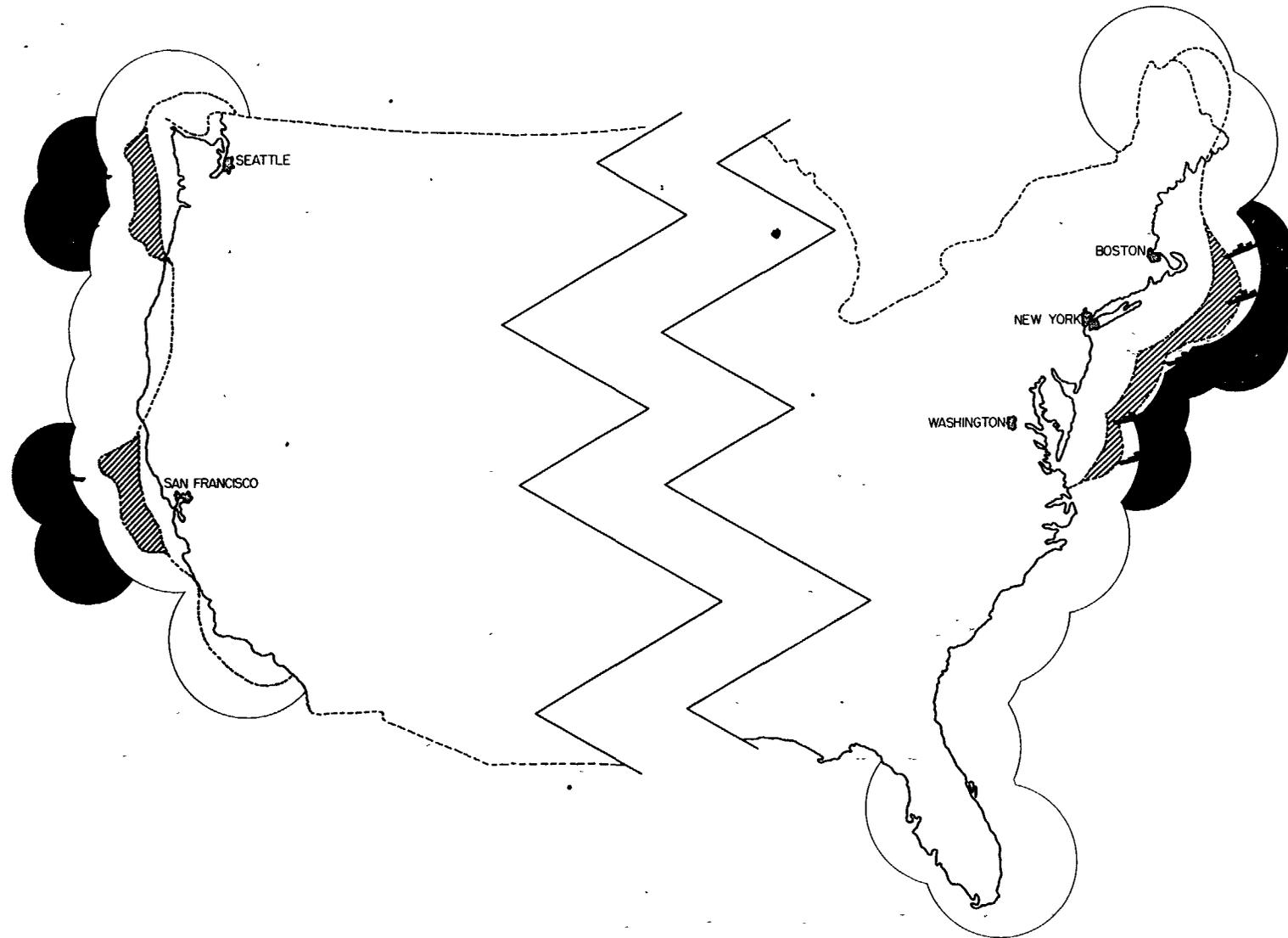

~~SECRET~~

~~SECURITY INFORMATION~~**RESTRICTED**AIRBORNE EARLY WARNING AND CONTROL

THE PROGRAMMED GROUND RADARS, AUGMENTED BY THE USE OF PICKET SHIPS, PROVIDES A REASONABLE RADAR DETECTION CAPABILITY. HOWEVER, WE STILL DO NOT HAVE SUFFICIENT DETECTION RANGE TO ACHIEVE DESIRED KILL PROBABILITY THROUGH PROVIDING THE REQUIRED TIME FOR AIR COMBAT.

AIRBORNE EARLY WARNING AND CONTROL HAS ALREADY BEEN PROVEN FEASIBLE OVER WATER. AIRBORNE EARLY WARNING AND CONTROL AIRCRAFT COULD OPERATE BEYOND THE COVERAGE OF THE LAND BASED AND PICKET SHIP RADARS A SUFFICIENT DISTANCE TO ALLOW THE INTERCEPTORS TO CONTACT THE ENEMY AT OR NEAR THE LIMIT OF THEIR RADIUS OF ACTION. THE AIRBORNE EARLY WARNING AND CONTROL AIRCRAFT, AS A RESULT OF OPERATIONAL CHARACTERISTICS, WILL MATERIALLY ASSIST IN ALLEVIATING THE CRITICAL LOW ALTITUDE ATTACK PROBLEM.

25

RESTRICTED~~SECURITY INFORMATION~~

PICKET SWIPS

AIR DEFENSE COMMAND

SECRET

AIRBORNE EARLY WARNING & CONTROL

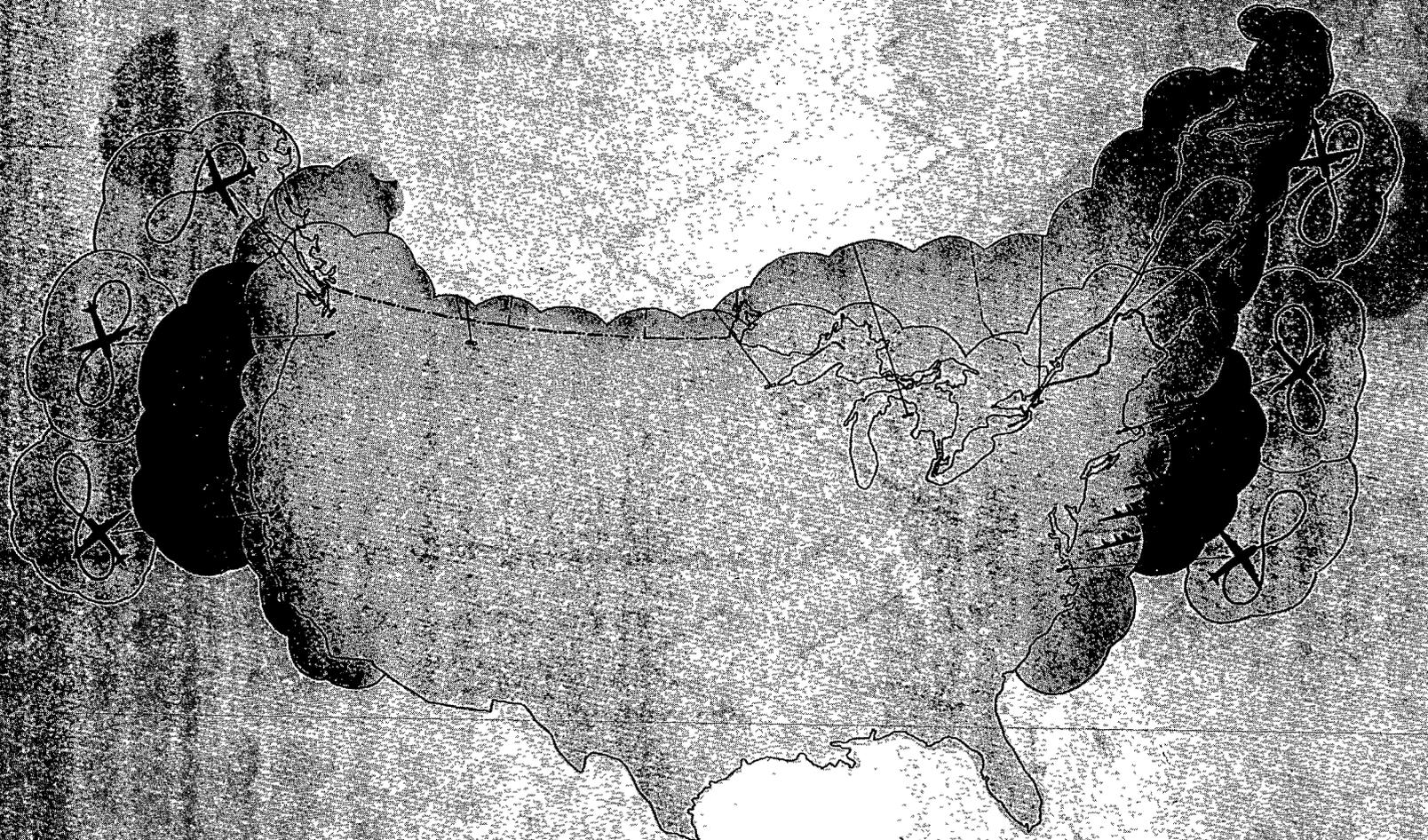

SECRET

~~SECURITY INFORMATION~~~~SECRET~~SEA AND AIRBORNE EARLY WARNING AND CONTROL

SHOWN HERE IS THE INITIAL OPERATIONAL PLAN FOR THE USE OF BOTH PICKET SHIPS AND AIRBORNE EARLY WARNING AND CONTROL AIRCRAFT AS A MEANS OF PROVIDING THE ESSENTIAL EXTENSION OF THE RADAR COVERAGE SEAWARD.

THE COVERAGE INDICATED ADJACENT TO THE SHORELINE IS AT 2,500 FEET AND FROM SHORE BASED RADAR. PICKET SHIP RADAR COVERAGE AT 2,500 FEET IS INDICATED IN VERY DARK SHADE. AIRBORNE EARLY WARNING RADAR COVERAGE AT 500 FEET IS INDICATED BY THE LARGER CIRCLES.

ALTHOUGH THE PRIMARY PURPOSE OF THIS PLAN IS THE COMPLETION OF THE SEAWARD EXTENSION OF THE DOUBLE RADAR PERIMETERS, THE MOBILITY OF THIS SYSTEM ALLOWS RAPID REDEPLOYMENT IF REQUIRED. FOR EXAMPLE: WITH A LITTLE WARNING A SECOND BARRIER OF AEW STATIONS WILL BE PUT INTO OPERATION ON AN EMERGENCY BASIS TO EXTEND COVERAGE OUT TO ABOUT 700 MILES.

THE AIR FORCE PRESENTLY HAS CONTRACTED FOR 57 LOCKHEED CONSTELLATION TYPE AIRCRAFT FOR THIS MISSION. SCHEDULED PRODUCTION WILL PERMIT ORGANIZATION OF THE FIRST SQUADRON EARLY IN 1954. THERE IS AT PRESENT ONE PICKET SHIP ALLOCATED FULL TIME AND ONE PART TIME ON THE EAST COAST. ABOUT TWENTY SHIPS ARE REQUIRED TO MAN THE NECESSARY TEN STATIONS CONTINUOUSLY.

~~SECRET~~~~SECURITY INFORMATION~~

~~SECRET~~

PICKET SHIP AND AEW DEPLOYMENT

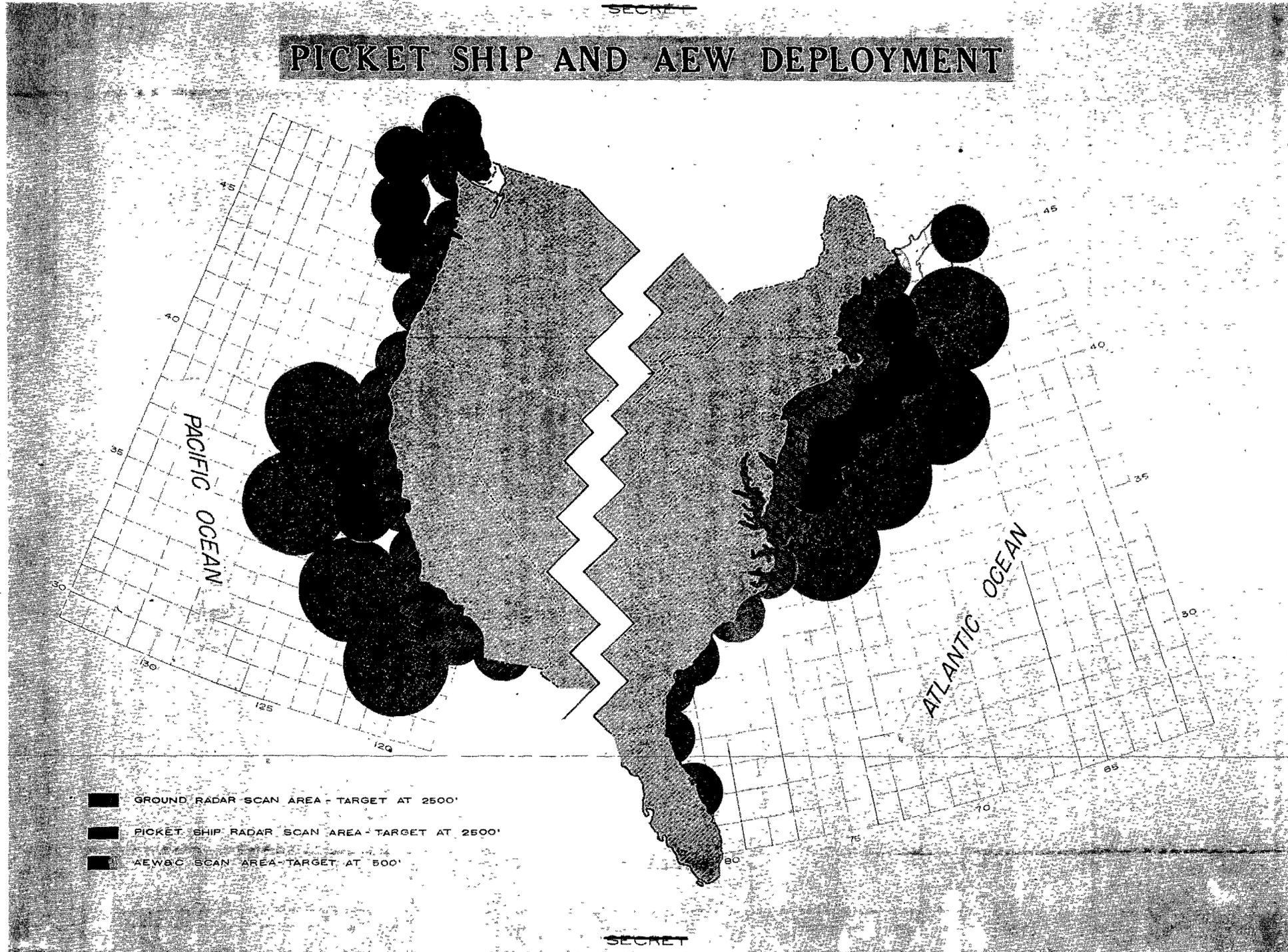

- GROUND RADAR SCAN AREA - TARGET AT 2500'
- PICKET SHIP RADAR SCAN AREA - TARGET AT 2500'
- AEW&C SCAN AREA - TARGET AT 500'

~~SECRET~~

~~SECURITY INFORMATION~~~~SECRET~~PASSIVE DETECTION

PASSIVE DETECTION METHODS INCLUDE DIRECTION FINDING AGAINST ENEMY AIRCRAFT RADAR EMISSIONS. RANGES CONSIDERABLY IN EXCESS OF RADAR LINE OF SITE HAVE BEEN OBTAINED WITH EXPERIMENTAL EQUIPMENT.

ADC HAS RECEIVED 9 EXPERIMENTAL SETS AND HAS THEM INSTALLED IN THE NEW YORK, SEATTLE, AND SAN FRANCISCO AREAS. TWENTY-NINE SETS ARE PROGRAMMED.

THESE EQUIPMENTS ARE DESIRED AT PERIPHERAL RADAR SITES TO EITHER DENY THE ENEMY THE USE OF THIS NAVIGATIONAL RADAR OR INCREASE OUR CHANCES OF DETECTION; AND ALSO, THEY WOULD BE OF GREAT VALUE IN CASE THE ENEMY ATTEMPTS TO JAM OUR RADARS.

27

~~SECRET~~~~SECURITY INFORMATION~~

PASSIVE DETECTION

~~SECRET~~
~~SECURITY INFORMATION~~

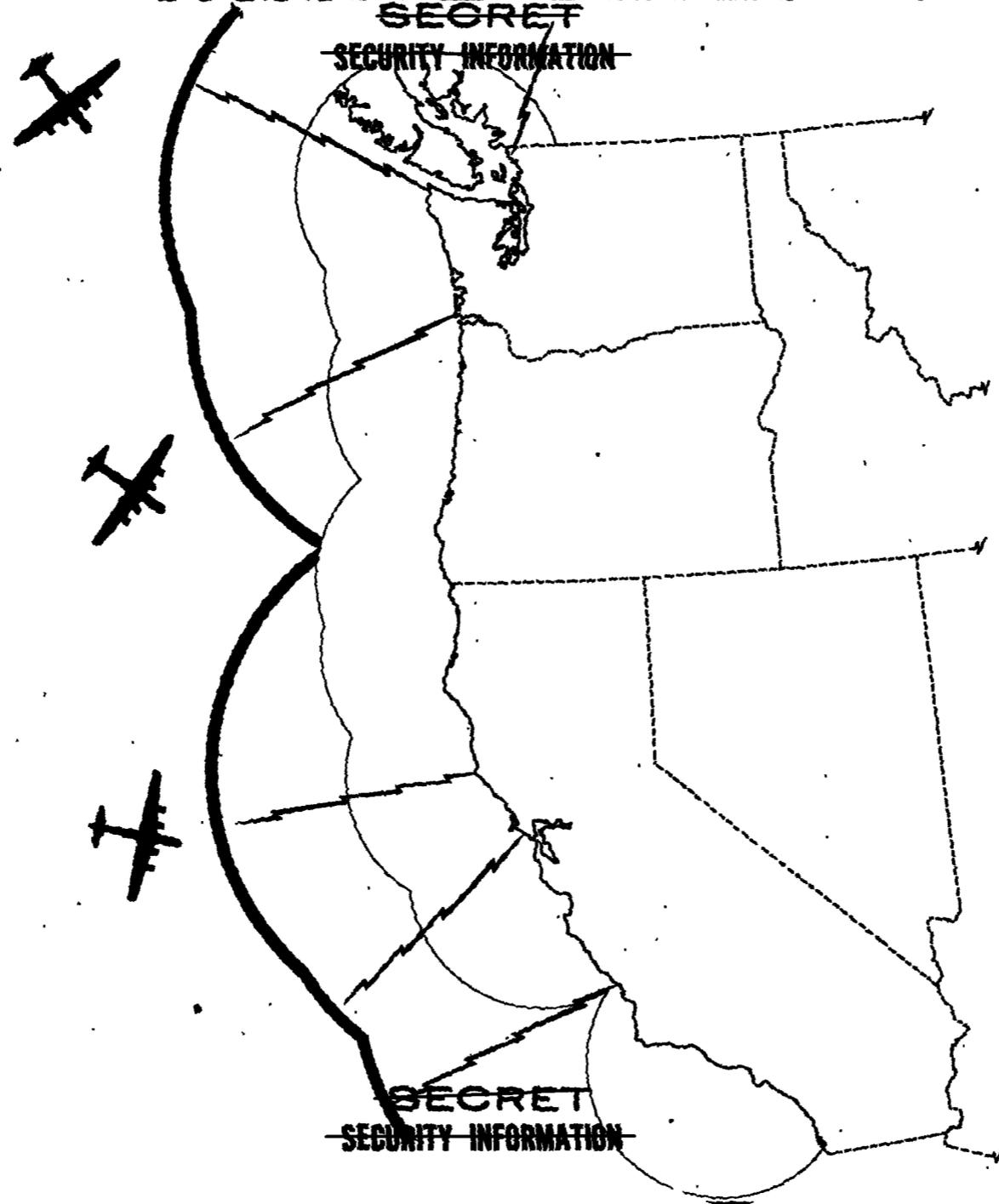

~~SECRET~~
~~SECURITY INFORMATION~~

ADIZ

NEXT IS THE PROBLEM OF IDENTIFYING THAT WHICH HAS BEEN DETECTED.

IN ANY DEFENSE SYSTEM, TIME IS OF PARAMOUNT IMPORTANCE AND IT THEREFORE IS INCUMBENT UPON THE SYSTEM TO FURNISH A MEANS OF RAPID IDENTIFICATION OF DETECTED AIRCRAFT AS FRIENDLY OR HOSTILE. WHEN WE REALIZE THAT THERE ARE OVER 25,000 AIRCRAFT FLIGHTS A DAY FROM FIELDS WITHIN THE U. S. WHERE THE CAA HAS FACILITIES, WE CAN SEE THE MAGNITUDE OF THE IDENTIFICATION PROBLEM WHICH FACES US IN AN INITIAL SURPRISE ATTACK.

ELECTRONIC IDENTIFICATION CANNOT BE RELIED UPON AT THE PRESENT TIME BECAUSE WE DO NOT HAVE A SECURE SYSTEM, AND BECAUSE IT IS AT PRESENT IMPRACTICABLE TO INSTALL IFF ON ALL COMMERCIAL OR CIVIL AIRCRAFT. THUS THE AIR DEFENSE SYSTEM MUST KEEP TRACK OF ALL FRIENDLY AIRCRAFT PENETRATING THE U. S. AND THOSE WITHIN CERTAIN CRITICAL AREAS. THIS INVOLVES THE ASSISTANCE AND COORDINATION OF THE CAA, THE DEPARTMENT OF TRANSPORT OF CANADA, AND OUR OWN MILITARY FLIGHT SERVICE. RAPID CORRELATION OF FLIGHT PLANS FURNISHED BY THESE AGENCIES MUST BE ACCOMPLISHED AND WHERE FRIENDLY IDENTITY IS NOT ESTABLISHED, THE NEXT ACTION, THAT OF INTERCEPTION, MUST BE TAKEN.

MY CHART SHOWS THE PRESENT AIR DEFENSE IDENTIFICATION ZONES OF THE U. S. AND CANADA. FRIENDLY AIRCRAFT USING THESE ZONES ARE REQUIRED TO FILE FLIGHT PLANS IN ADVANCE OF PENETRATION. THESE ZONES ARE, BY NO MEANS, THE ULTIMATE. AS OUR PROGRESSIVE CAPABILITIES WARRANT, CHANGES AND ADDITIONS WILL BE MADE UNTIL A SYSTEM IS ESTABLISHED WHEREIN UNCLEARED PENETRATION CONSTITUTES A HOSTILE ACT.

AIR DEFENSE COMMAND

AIR DEFENSE IDENTIFICATION ZONES

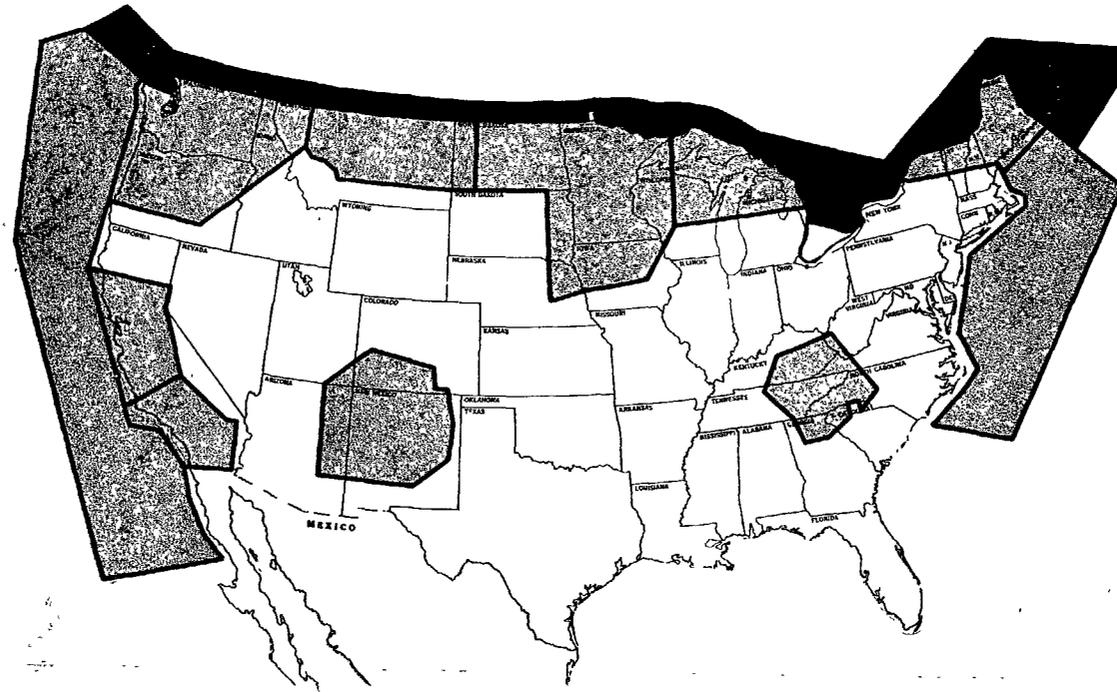

~~SECURITY INFORMATION~~~~RESTRICTED~~CORRIDORS AND SCAT

NOTE FIRST ON THIS CHART THE CORRIDORS ACROSS THE CANADIAN BORDER AND THE RADIAL CORRIDORS ON THE COASTAL APPROACHES.

NEGOTIATIONS ARE NOW UNDERWAY TO ESTABLISH THESE CORRIDORS AND WE FEEL THEY ARE A MUST FOR ADEQUATE IDENTIFICATION.

THE COASTAL RADIAL CORRIDORS REQUIRE POWERFUL LOW FREQUENCY HOMING BEACONS. EACH AIRCRAFT CLEARED FOR ENTRY WILL HAVE ITS CORRIDOR AND SECURITY CHECK MANEUVER ASSIGNED AT THE TAKE-OFF BASE. THIS SYSTEM WAS TESTED WITH THE WHOLEHEARTED COOPERATION OF THE CAA AND THE CIVIL AIR LINES, IN THE SAN FRANCISCO AREA. THE RESULTS ARE VERY GRATIFYING.

NEXT NOTE THE DOTS. THESE REPRESENT INNER DEFENSE ZONES WHICH ARE NOW BEING ESTABLISHED AND IN WHICH ANTI-AIRCRAFT WEAPONS ARE LOCATED. WHEN HOSTILE AIRCRAFT ARE DETECTED THESE ZONES BECOME PROHIBITED AREAS AND ALL WEAPONS ARE TO BE FREED AGAINST UNCLEAR AIRCRAFT. THIS IS ANOTHER STEP TAKEN TO ELIMINATE PAST RESTRICTIONS ON AA FIRE. OUR BASIC POLICY IS TO PERFECT THE AIR TRAFFIC CONTROL SYSTEM TO THE POINT WHERE ALL WEAPONS ARE FREE TO ENGAGE ANY AIRCRAFT EXCEPT THOSE SPECIFICALLY CLEARED TO PROCEED THROUGH THE DEFENDED AREAS.

FOR EMERGENCY USE WE NOW HAVE A COORDINATED PLAN FOR THE SECURITY CONTROL OF AIR TRAFFIC KNOWN AS SCAT. THIS PLAN PROVIDES FOR THE TEMPORARY DIVERSION OR GROUNDING OF ALL UNESSENTIAL CIVIL AND MILITARY AIR TRAFFIC AND THEN A CAREFULLY REGULATED FLOW OR PRIORITY FLIGHTS. THIS ACTION IS ESSENTIAL TO THE SAFETY OF THE AIRCRAFT INVOLVED AND IS NECESSARY TO AVOID OVER SATURATION OF OUR IDENTIFICATION SYSTEM. THE POLICY, HOWEVER, IS TO PERMIT A CONTROLLED MAXIMUM FLOW OF AIR TRAFFIC - A VITAL PART OF THE U. S. ECONOMY IN PEACE OR WAR.

~~RESTRICTED~~~~SECURITY INFORMATION~~

AIR DEFENSE IDENTIFICATION ZONES

SECRET

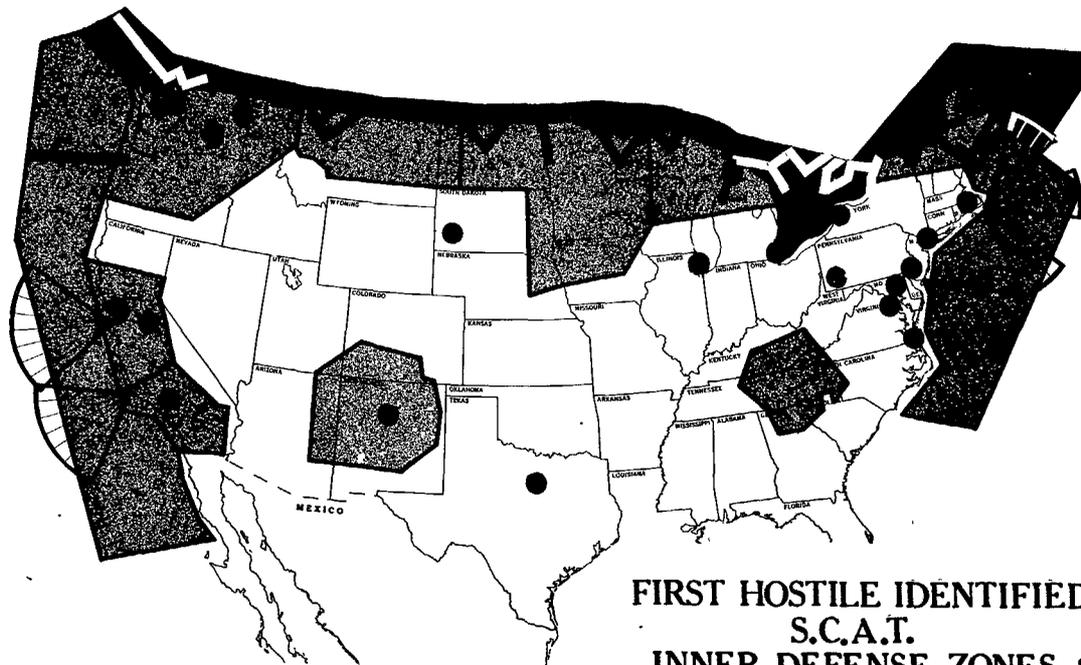

FIRST HOSTILE IDENTIFIED
 S.C.A.T.
 INNER DEFENSE ZONES
 IN EFFECT

SECRET

1. Clearly identify each of the zones.

2. Assign security control to each zone.

(2) Assign AAA equipment under "Warning Box"

(3) Position Cremonese - present position - identify.

3. Equipment for charging one agency with identification responsibility.

4. Use the term "Warning Box" for identification and identification by manual voice radio. Improvements will be discussed as we progress.

~~SECURITY INFORMATION~~**SECRET**ELECTRONIC IDENTIFICATION

THE BASIC IFF MARK X SYSTEM PROVIDES NO GENUINE IFF SECURITY BUT IT CAN ASSIST CONSIDERABLY IN ALLEVIATING THE IDENTIFICATION PROBLEM. OF MAJOR IMPORTANCE TO ADC IS ITS USE TO EXTEND THE EFFECTIVE RADAR RANGE FOR CONTROL OF INTERCEPTORS.

AIRBORNE TRANSPONDERS ARE AVAILABLE IN FIGHTER AIRCRAFT. MARK X INTERROGATOR RESPONDERS ARE NOW INSTALLED AT 93% OF THE PERMANENT RADAR STATIONS.

RETROFITTING OF ALL FIGHTER AND ADMINISTRATIVE AIRCRAFT, WITH EXCEPTION OF C-45's AND C-47's (NOT SCHEDULED FOR RETROFIT) IS 85% COMPLETE. THE REMAINING 15% CONSISTS PRIMARILY OF ADMINISTRATIVE TYPES.

THE SECURITY AND SELECTIVE IDENTIFICATION FEATURE OF THIS EQUIPMENT IS STILL IN THE DEVELOPMENT STAGE. THIS FEATURE IS ESSENTIAL IN ORDER TO INCREASE THE SECURITY OF THE SYSTEM.

30

SECRET~~SECURITY INFORMATION~~

~~SECRET~~

IDENTIFICATION FRIEND OR FOE MARK X SYSTEM

NOW

BEACON ASSIST ON INTERCEPTORS
AIDS IDENTIFICATION.

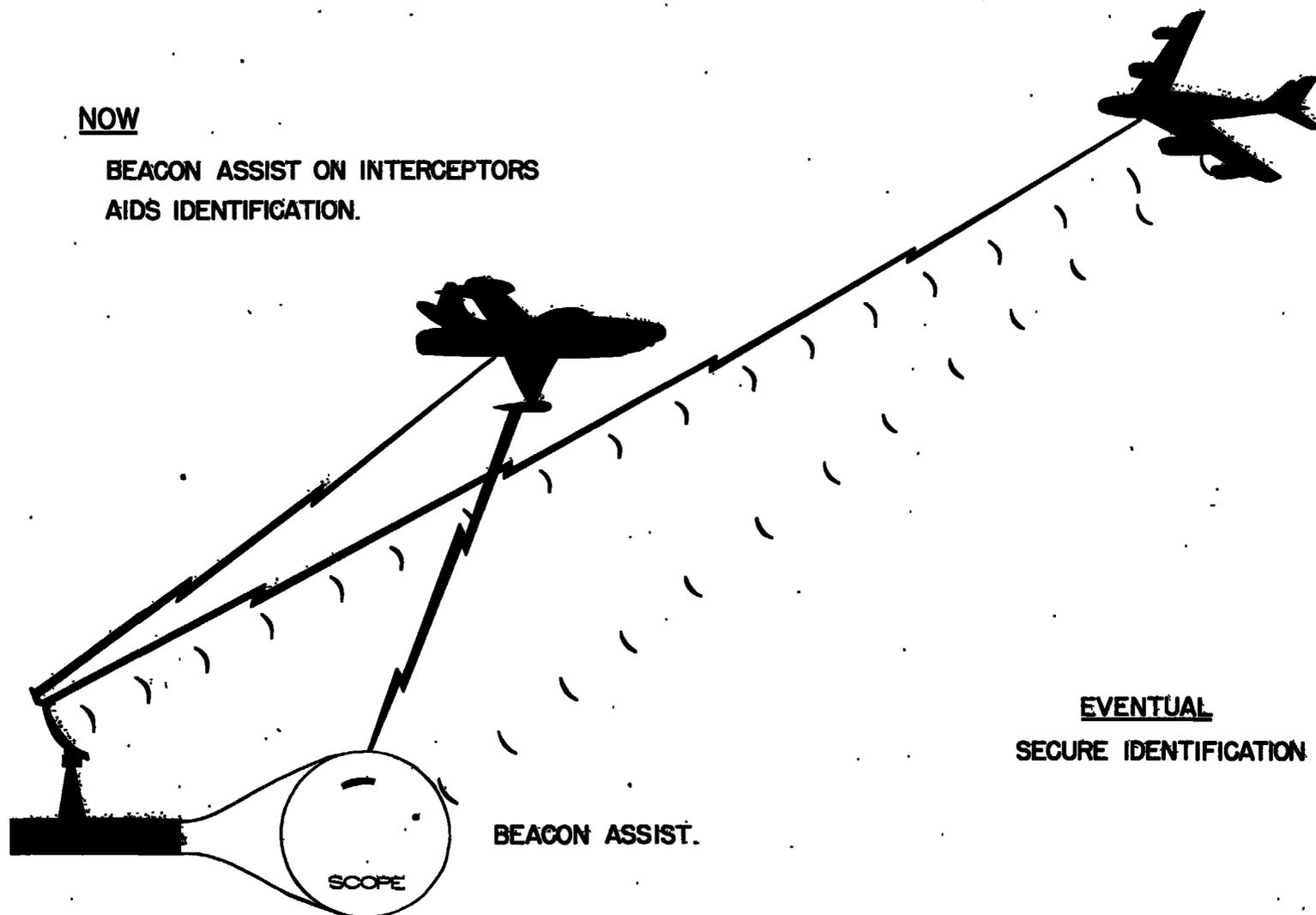

EVENTUAL
SECURE IDENTIFICATION

~~SECRET~~

~~SECURITY INFORMATION~~~~SECRET~~AIRBORNE INTERROGATION

THE AIR DEFENSE COMMAND HAS NO AIRBORNE INTERROGATION CAPABILITY. BY THIS I MEAN THAT IT IS IMPOSSIBLE FOR AN AIRBORNE INTERCEPTOR PILOT DURING BAD WEATHER OR AT NIGHT TO DISCRIMINATE BETWEEN FRIEND OR FOE IN A MASS AIR BATTLE. EVEN THOUGH SEVERAL SYSTEMS ARE UNDER CONSIDERATION, NONE ARE PRESENTLY AVAILABLE, AND OUR INTERCEPTORS ARE WORKING UNDER A SERIOUS HANDICAP UNTIL THIS EQUIPMENT IS AVAILABLE.

THE E-9 FIRE CONTROL SYSTEM WILL BE THE FIRST PRODUCTION FIRE CONTROL SYSTEM TO INCORPORATE AIR-TO-AIR IFF. HOWEVER, THESE ARE NOT EXPECTED TO BE AVAILABLE TO ADC UNTIL EARLY 1955. A RETROFIT PROGRAM IN THE EARLY FIRE CONTROL SYSTEMS IS EXPECTED.

~~SECRET~~~~SECURITY INFORMATION~~

AIR DEFENSE COMMAND

~~SECRET~~

AIRBORNE INTERROGATORS

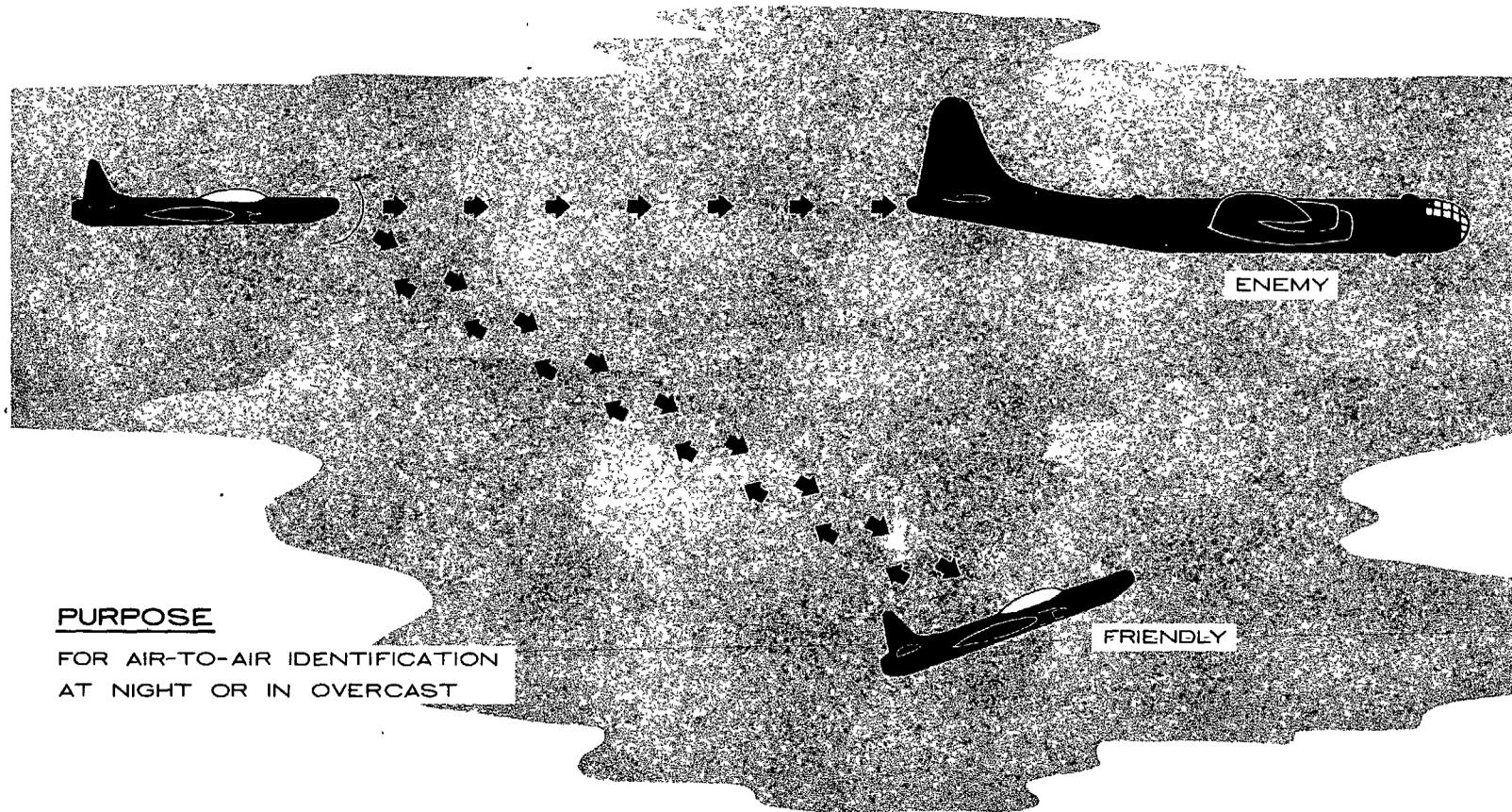

PURPOSE

FOR AIR-TO-AIR IDENTIFICATION
AT NIGHT OR IN OVERCAST

~~SECRET~~

FREE SPACES

UNDER PEACETIME CONDITIONS THE TREMENDOUS AMOUNT OF AIR TRAFFIC IN THE VICINITY OF LARGE METROPOLITAN AREAS CAUSES AN IMPOSSIBLE IDENTIFICATION PROBLEM. THUS NECESSITATING THE USE OF FREE SPACE AREAS.

THIS CHART DEPICTS THE SITUATION WITHIN THE 28TH AIR DIVISION AREA SURROUNDING SAN FRANCISCO. THE CHART INDICATES THE RADAR COVERAGE, THE FREE SPACE AND THE AIR DEFENSE IDENTIFICATION ZONE BOUNDARY. THE DIVISION COMMANDER IS MAINLY CONCERNED WITH PENETRATION OF THE ADIZ BOUNDARY, THEREFORE, NORMALLY, HE CAN AFFORD TO TAKE THE CALCULATED RISK OF DISREGARDING ALL RADAR AND GROUND OBSERVER INFORMATION ORIGINATING WITHIN THE FREE SPACE.

THE DIVISION COMMANDER MAY ALTER THE LIMITS OF, OR ABOLISH, THIS FREE SPACE AREA AS THE SITUATION DICTATES.

FREE AREA

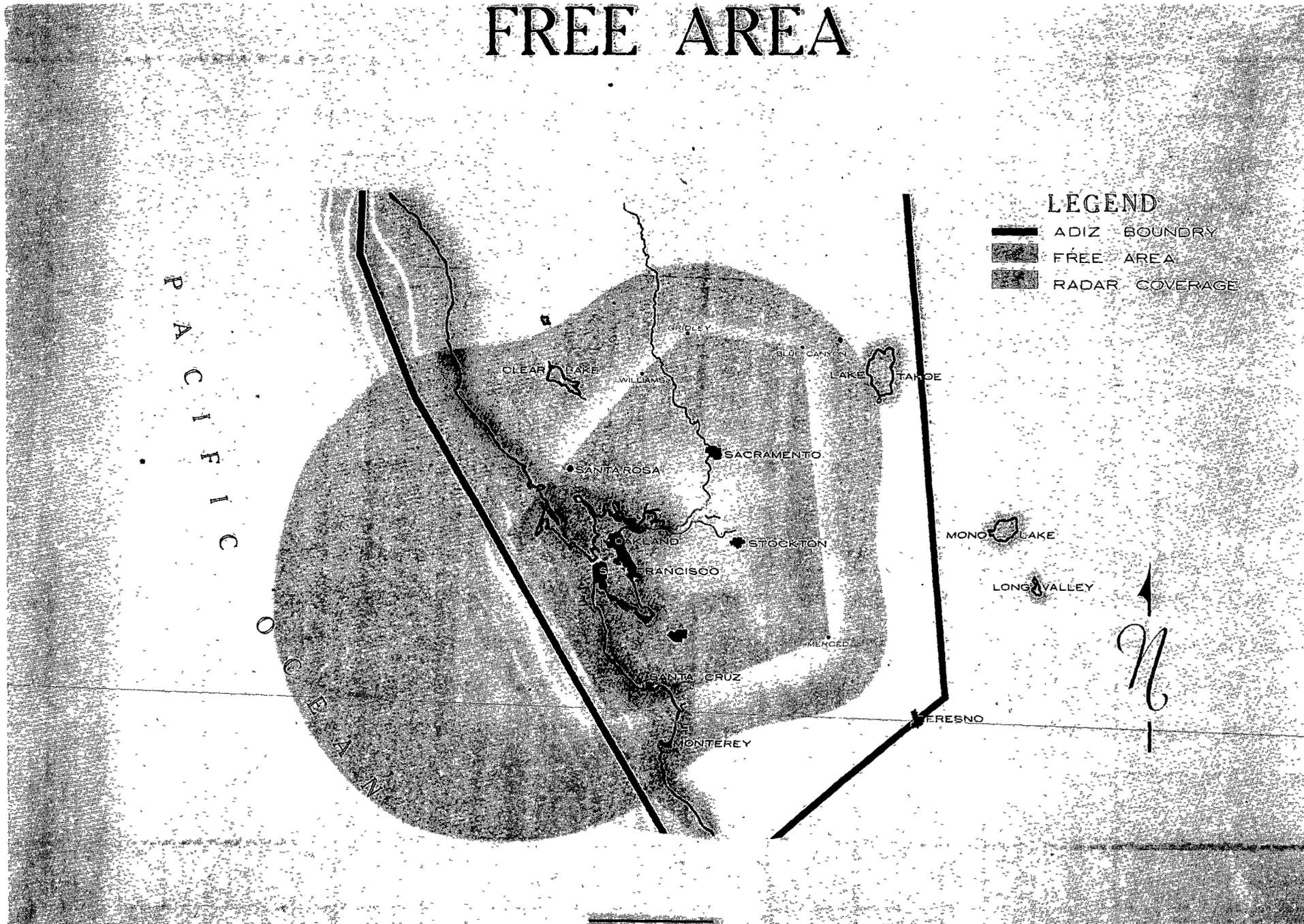

LEGEND

- ADIZ BOUNDARY
- FREE AREA
- RADAR COVERAGE

~~SECURITY INFORMATION~~**SECRET**RULES OF ENGAGEMENT

AFTER IDENTIFICATION OF AIRBORNE OBJECTS AS HOSTILE OR OF QUESTIONABLE CHARACTER, INTERCEPTION BEGINS. TO PROVIDE GUIDANCE FOR OPERATIONAL DECISIONS SUCH AS WHEN AND WHEN NOT TO OPEN FIRE, RULES OF ENGAGEMENT HAVE BEEN PROMULGATED. THESE INSTRUCTIONS ARE IN EFFECT NOW. ALL AIR DEFENSE UNITS AND PERSONNEL HAVE BEEN THOROUGHLY BRIEFED IN THEIR PURPOSE AND INTENT.

AS NOTED ON THE CHART, AIR DEFENSE FORCES ARE AUTHORIZED TO DESTROY AIRCRAFT IN FLIGHT WITHIN THE SOVEREIGN BOUNDARIES AND THE COASTAL ADIZ'S OF THE UNITED STATES WHICH ---:

1. COMMIT HOSTILE ACTS.
2. ARE MAINIFESTLY HOSTILE IN INTENT. THIS CONDITION IS DECLARED WHEN THE PATTERN OF INCOMING UNIDENTIFIED AIRCRAFT, THAT IS, SIZE OF FORMATION, HEIGHT, SPEED, DIRECTION AND/OR SIMULTANEOUS PENETRATIONS, INDICATE BEYOND A REASONABLE DOUBT THAT THE AIRCRAFT ARE MANIFESTLY HOSTILE.
3. BEAR THE MILITARY INSIGNIA OF THE USSR, UNLESS PROPERLY CLEARED OR OBVIOUSLY IN DISTRESS.

TO ASSURE DESTRUCTION OF THE MAXIMUM NUMBER OF ATTACKING AIRCRAFT, A FAMILY OF WEAPONS MUST BE USED. THIS IS NECESSARY FOR FLEXIBILITY, THE ADEQUATE COUNTERING OF MANY DIFFERENT ATTACK STRATEGIES, THE COUNTERING OF COUNTER-MEASURES; AND TO ASSURE INCREASING MASS OF WEAPONS AS THE ATTACKING FORCE NEARS VITAL TARGETS. THIS FAMILY IS INTERCEPTORS, LONG RANGE MISSILES, LOCAL WEAPONS AND COUNTER-COUNTERMEASURES. EACH WILL BE DISCUSSED AS WE PROGRESS THROUGH THE PRESENTATION.

SECRET~~SECURITY INFORMATION~~

~~SECRET~~
~~SECURITY INFORMATION~~

RULES OF ENGAGEMENT

AIR DEFENSE FORCES ARE AUTHORIZED TO DESTROY AIRCRAFT IN FLIGHT WITHIN THE SOVEREIGN BOUNDARIES AND THE COASTAL ADIZ'S OF THE UNITED STATES WHICH:

- 1. COMMIT HOSTILE ACTS.
- 2. ARE MANIFESTLY HOSTILE IN INTENT.
- 3. BEAR THE MILITARY INSIGNIA OF THE USSR.

(UNLESS PROPERLY CLEARED OR OBVIOUSLY IN DISTRESS)

~~SECRET~~
~~SECURITY INFORMATION~~

~~SECURITY INFORMATION~~**SECRET**FIGHTER DEPLOYMENT

ALL WEAPONS MUST BE PROPERLY LOCATED IN ORDER THAT THE INTERCEPTION OF HOSTILE AIRCRAFT CAN BE ACCOMPLISHED RAPIDLY AND EFFECTIVELY. THIS CHART INDICATES THE PROGRAMMED DEPLOYMENT OF THE 57 INTERCEPTOR SQUADRONS ALLOCATED TO THE AIR DEFENSE COMMAND FROM THE AIR FORCE 143 WING PROGRAM. ALL SQUADRONS ARE TO BE EQUIPPED WITH ALL WEATHER INTERCEPTORS.

THESE INTERCEPTORS WILL BE CAPABLE OF INTERCEPTIONS AND DESTRUCTION OF HOSTILES IN ANY WEATHER, DAY AND NIGHT. AND, WHILE THE INTERCEPTOR IS EXTREMELY COSTLY AND COMPLICATED, THE BASIC DEFENSE FORCE MUST CONSIST OF THESE TYPES. DAY FIGHTERS OF OTHER COMMANDS AND SERVICES WILL AUGMENT THIS FORCE AGAINST MASS ATTACKS IN GOOD WEATHER.

WE'VE ALL DISCUSSED THE LONG RANGE INTERCEPTOR CONCEPT VERSUS THE SHORT RANGE, WHEN ONE CONSIDERS A GIVEN MONETARY CEILING FOR INTERCEPTORS, STUDIES SHOW THAT A GREATER OVER-ALL KILL, PER DOLLAR, IS REALIZED IF INTERCEPTORS WITH RADIUS OF ACTION OF 350 - 500 MILES COMPOSE THE DEFENSE FORCE. THE BASIC REASON IS THE "SNOW-BALLING" COST OF TRYING TO GET MORE RANGE. FOR EXAMPLE, - FOR THE SAME TOTAL PRICE YOU CAN BUY A FORCE OF 1500 INTERCEPTORS OF 500 MILE RADIUS OF ACTION -- BUT ONLY 800 - 900 WITH RANGES OF 800 - 1000 MILE RADIUS; AND, THE OVERALL KILL CAPABILITY IS HIGH IN FAVOR OF THE LARGER NUMBER OF SHORTER RANGE INTERCEPTORS.

SECRET~~SECURITY INFORMATION~~

~~SECURITY INFORMATION~~ ~~SECRET~~

FIGHTER DEPLOYMENT

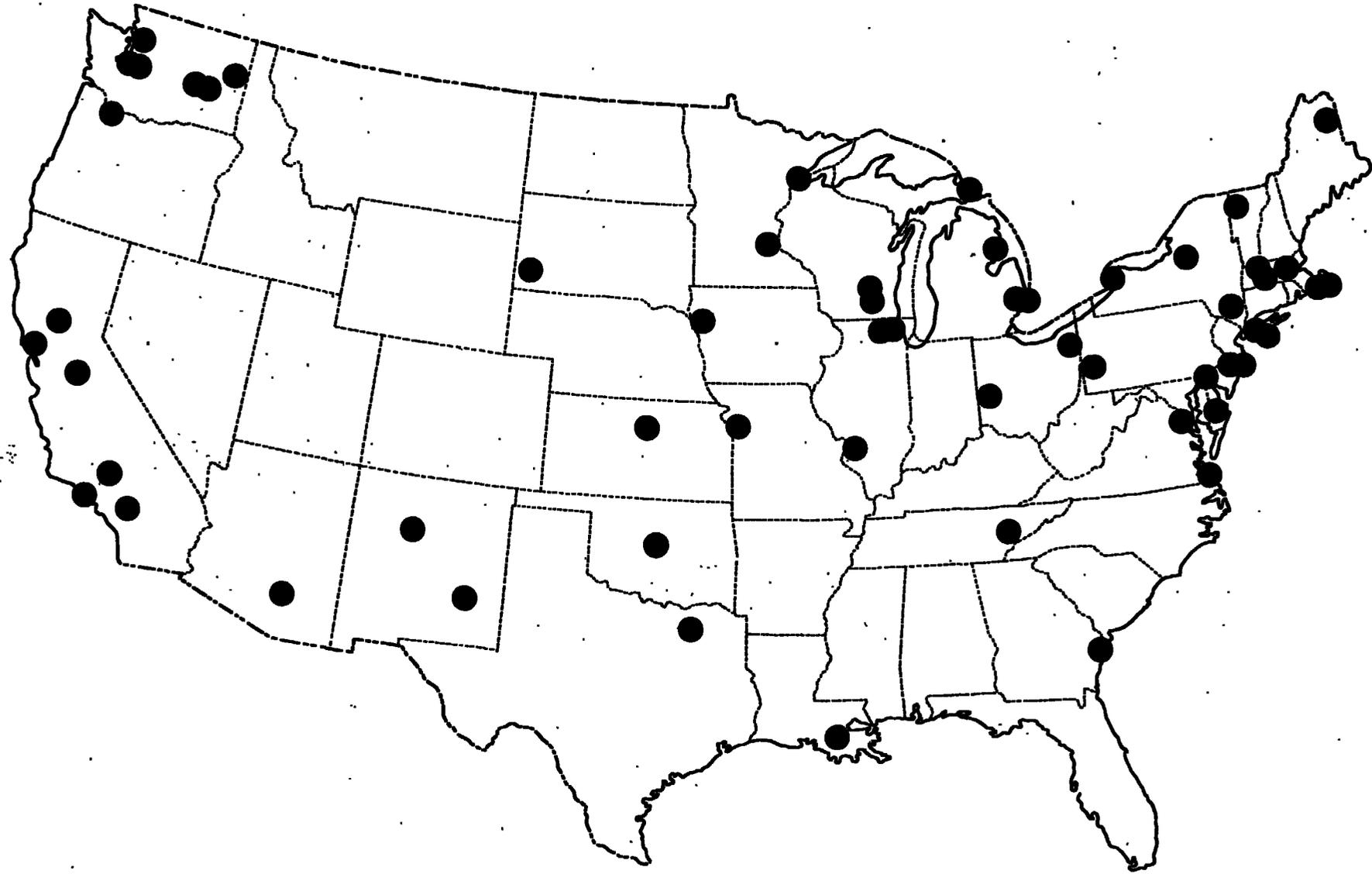

~~SECRET~~ ~~SECURITY INFORMATION~~

~~SECURITY INFORMATION~~~~SECRET~~CURRENT FIGHTER DEPLOYMENT

SUPERIMPOSED ON THE PREVIOUS CHART, WE HAVE THE DEPLOYMENT OF THE 50 SQUADRONS AS OF JUNE THIS YEAR.

THE 4 F-51 SQUADRONS ARE INDICATED BY THIN LINED CONCENTRIC CIRCLES. THESE AIRCRAFT ARE THE PROPELLER DRIVEN MUSTANG FIGHTERS OF WORLD WAR II, AND LACK THE PERFORMANCE CHARACTERISTICS REQUIRED; BUT THEY ARE CERTAINLY BETTER THAN NOTHING.

THE UNBROKEN HOLLOW CIRCLES REPRESENT 17 SQUADRONS EQUIPPED WITH OTHER TYPE JET AIRCRAFT. THEY ARE VERY CAPABLE FIGHTER AIRCRAFT BUT THEY ARE NOT EQUIPPED FOR COMPLETELY ALL-WEATHER OPERATION.

THE BROKEN HOLLOW CIRCLES INDICATE THE 29 SQUADRONS EQUIPPED WITH ALL-WEATHER AIRCRAFT. ALL-WEATHER FIGHTER INTERCEPTOR AIRCRAFT ARE DESIGNED FOR THE AIR DEFENSE COMMAND MISSION AND ARE CAPABLE OF INTERCEPTION AND DESTRUCTION OF THE TARGET SOLELY BY INSTRUMENT FLYING. INADEQUATE PRODUCTION OF THESE AIRCRAFT THUS FAR, LIMITS THE NUMBER OF AIRCRAFT IN THESE SQUADRONS TO ABOUT 12 INSTEAD OF 25 EACH.

THIS FIGHTER FORCE WILL STEADILY BECOME MORE POTENT, HOWEVER, WITH RECEIPT OF NEW ALL-WEATHER JETS.

~~SECRET~~~~SECURITY INFORMATION~~

~~SECRET SECURITY INFORMATION~~

FIGHTER DEPLOYMENT

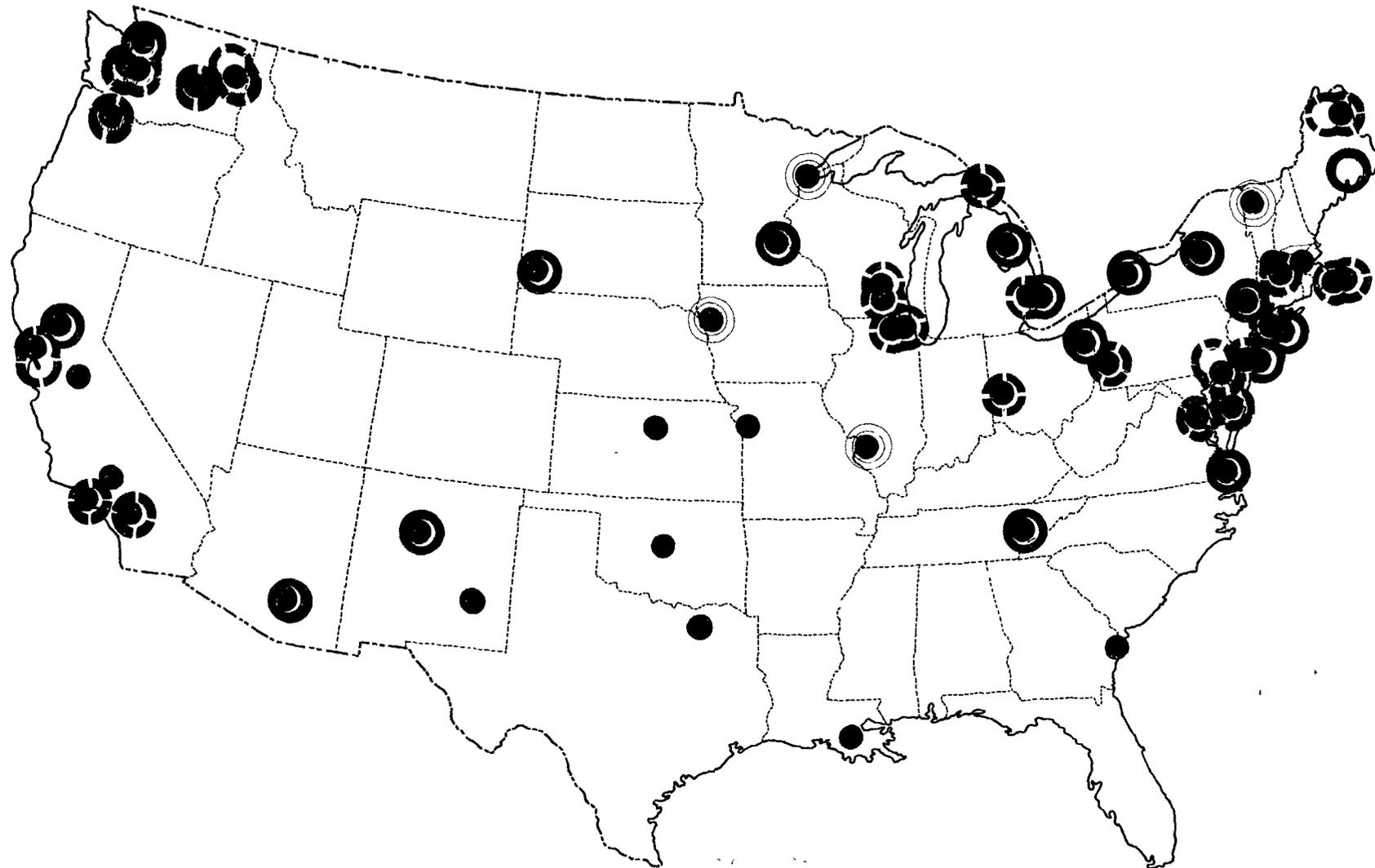

~~SECRET SECURITY INFORMATION~~

~~SECURITY INFORMATION~~~~SECRET~~FIGHTER AIRCRAFT INVENTORY

HERE IS THE AIR DEFENSE COMMAND FIGHTER AIRCRAFT INVENTORY OF 1 JULY LAST YEAR, AND PROJECTED TO 1 JULY 1954.

THE TOP BROKEN LINE INDICATES THE REQUIREMENT BASED ON 25 AIRCRAFT FOR EACH SQUADRON AUTHORIZED.

AT THE BOTTOM ARE THE ALL-WEATHER JET INTERCEPTOR AIRCRAFT WHICH ARE ESSENTIAL TO THE ACCOMPLISHMENT OF OUR MISSION. OUR PRESENT UNENVIABLE POSITION IS DUE TO THE WELL KNOWN PRODUCTION DELAYS. THE DROP INDICATED WAS DUE TO A SQUADRON TRANSFER-OVERSEAS, AND TO THE WITHDRAWAL FOR MODIFICATION, OF ALL THE NORTHROP F-89 AIRCRAFT.

THE MIDDLE SHADED BLOCK INDICATES OTHER JETS AND THE TOP SHADED BLOCK CONVENTIONAL FIGHTERS. THESE WILL ALL BE REPLACED EVENTUALLY.

THE SPACE BETWEEN THE TOP BROKEN LINE AND THE SOLID LINE INDICATES, OF COURSE, THE INVENTORY SHORTAGE.

NOW, LET'S LOOK AT THE ALL-WEATHER PICTURE BASED ON OUR ACTUAL NEED RATHER THAN ON AIRCRAFT AUTHORIZATION.

TO ACCOMPLISH THE ASSIGNED MISSION, WE SHOULD HAVE TODAY, 1425 ALL-WEATHER FIGHTERS. PROJECTED INVENTORY FOR JUNE INDICATES WE WILL HAVE 372 ALL-WEATHER FIGHTERS. THIS IS ONLY 26% OF OUR NEEDS.

~~SECRET~~~~SECURITY INFORMATION~~

FIGHTER AIRCRAFT INVENTORY

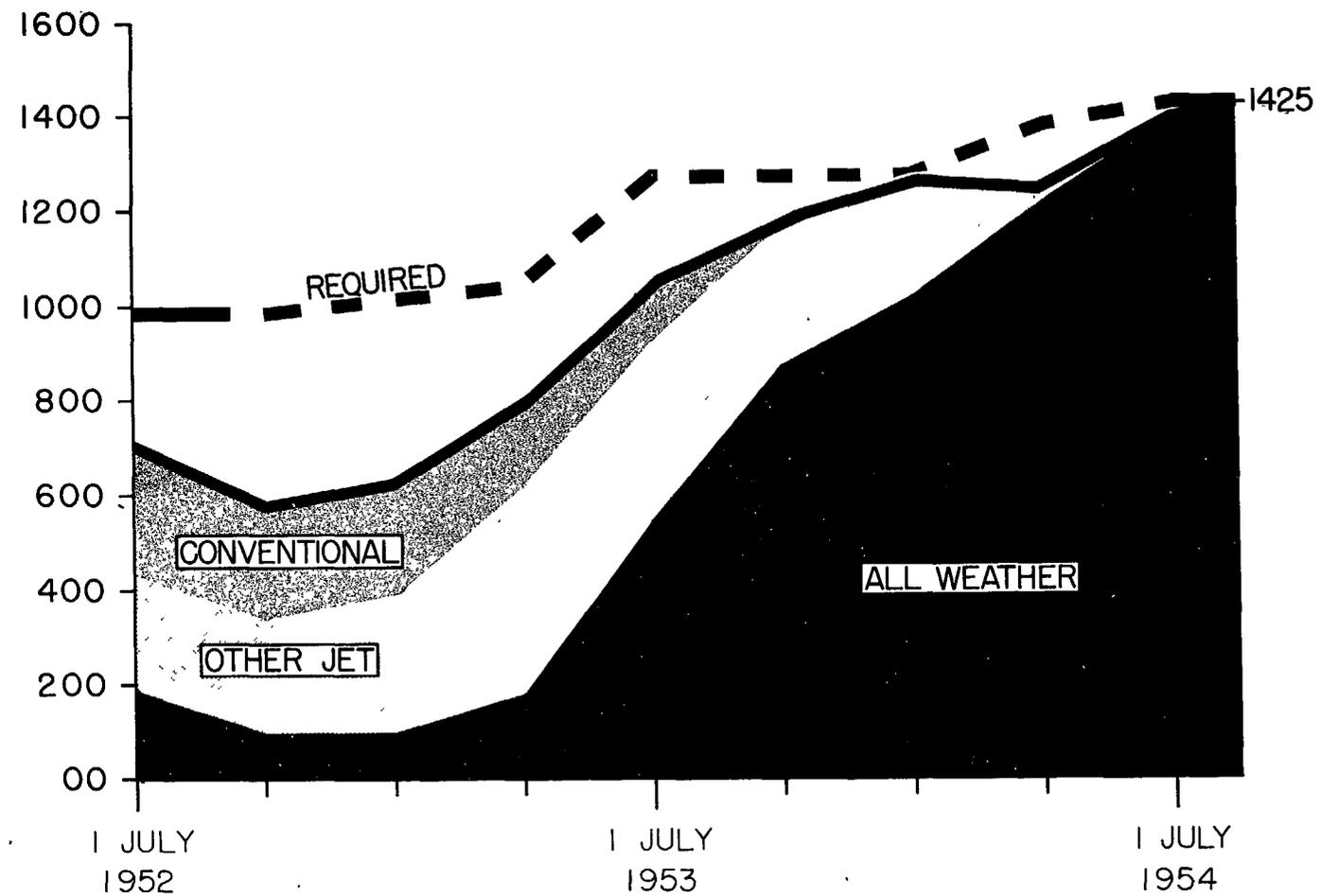

~~SECURITY INFORMATION~~~~SECRET~~FIGHTER PROGRAM BY TYPE AIRCRAFT

THIS CHART SHOWS DECEMBER 1955 POSITION OF FIGHTER SQUADRONS BY TYPE AIRCRAFT.

THE ALL WEATHER INTERCEPTORS WILL CARRY 2.75 INCH AERIAL ROCKETS AS MAIN ARMAMENT; WITH THE F-89 CARRYING SEVERAL GAR-~~E~~ AIR-TO-AIR MISSILES AS WELL.

AS THE DEMAND FOR IMPROVED PERFORMANCE OF ALL WEATHER INTERCEPTORS INCREASES SO DOES THE COMPLEXITY OF THESE WEAPONS. MAINTENANCE PERSONNEL MUST BE MORE SKILLED, PILOTS MORE EXPERIENCED. THE TRAINING REQUIREMENTS HAVE INCREASED IN COURSE DURATION AND DETAIL FOR ALL PERSONNEL INVOLVED IN THESE PROGRAMS.

~~SECRET~~~~SECURITY INFORMATION~~

AIR DEFENSE COMMAND

SECRET

FIGHTERS - BY TYPE

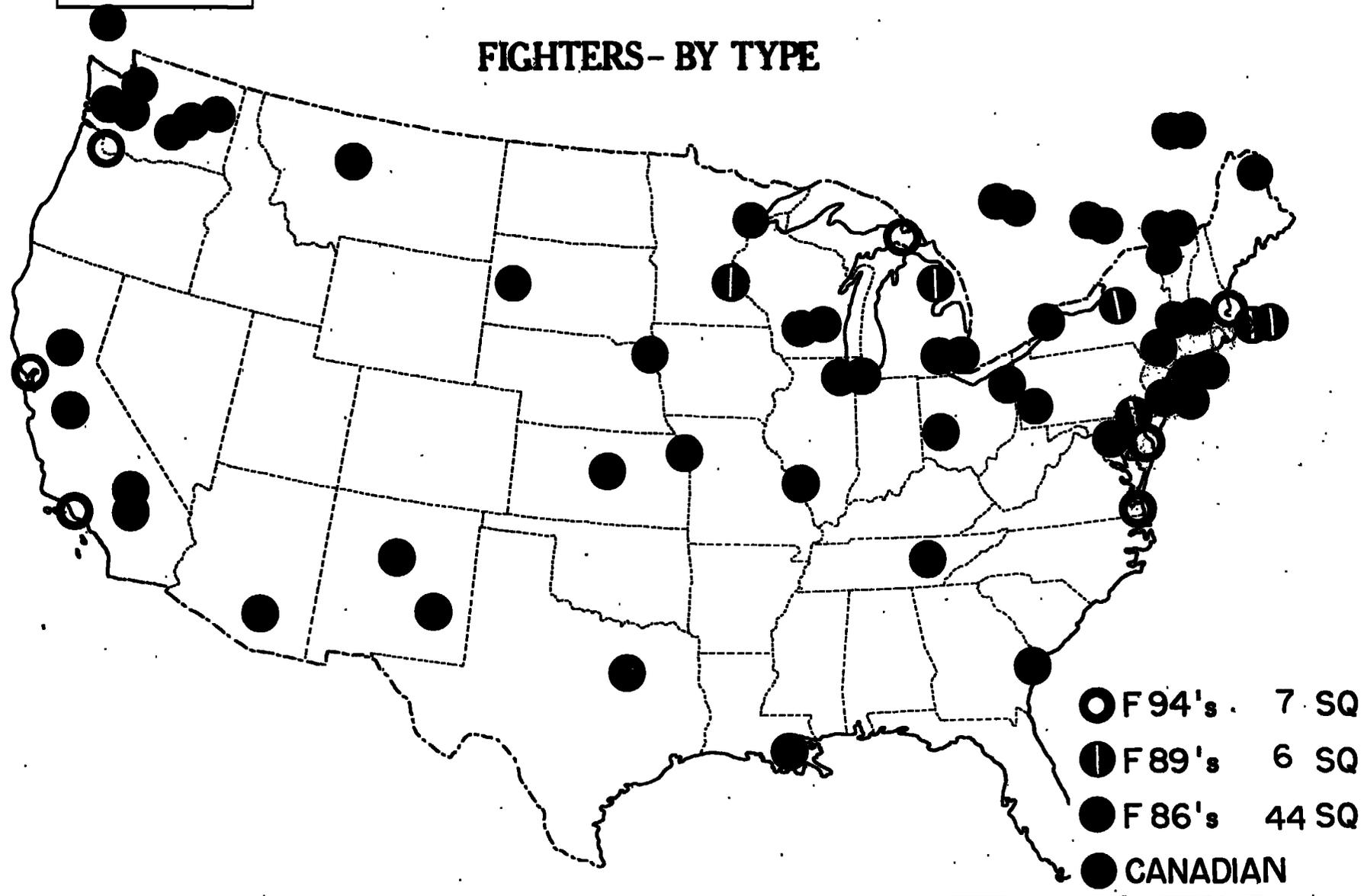

SECRET

~~SECURITY INFORMATION~~~~SECRET~~ANG BACKUP

THE HOLLOW BLACK CIRCLES INDICATE THE PREVIOUSLY SHOWN ULTIMATE POSITION OF REGULAR FIGHTER DEPLOYMENT - THE SOLID BLACK CIRCLES, THE 52 ANG FIGHTER INTERCEPTOR SQUADRONS EARMARKED FOR ADC. OF THESE 52 SQUADRONS 19 WILL BE RETAINED FOR AN ESTIMATED D PLUS 3 MONTHS AND THEN BE ASSIGNED TO TAG.

WHILE THE AIR NATIONAL GUARD UNITS MAY HAVE LITTLE CAPABILITY AGAINST AN INITIAL SURPRISE ATTACK, THEY ARE OF CONSIDERABLE VALUE IF WE HAVE EVEN A FEW HOURS WARNING. IN ADDITION, THESE SQUADRONS WILL PROVIDE A POOL OF TRAINED PERSONNEL AND EQUIPMENT FOR USE DEPENDING UPON THE SITUATION.

38

~~SECRET~~~~SECURITY INFORMATION~~

AIR DEFENSE COMMAND

SECRET

AIR NATIONAL GUARD BACK-UP

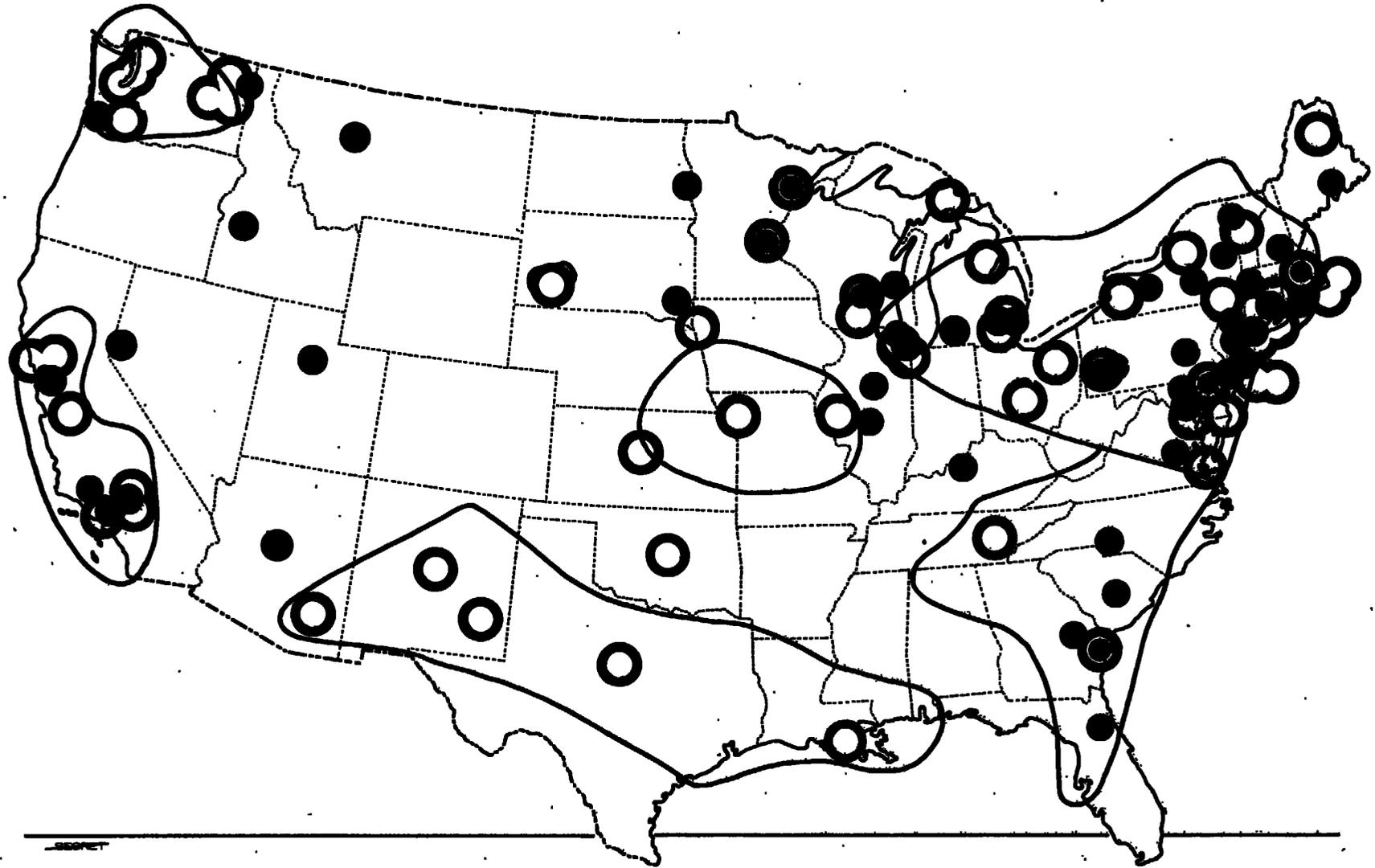

SECRET

~~SECURITY INFORMATION~~~~SECRET~~INTERCEPTOR ARMAMENT

THE DESTRUCTION OF A HOSTILE AIRCRAFT IS BASICALLY A FUNCTION OF EITHER THE ARMAMENT CARRIED BY THE INTERCEPTOR, OR THE WARHEAD OF THE LONG RANGE MISSILES, AND THE CAPABILITY OF THE ANTI-AIRCRAFT BATTALIONS.

THE PRESENT DAY INTERCEPTORS ARE EQUIPPED WITH 4 TO 6 50 CALIBER MACHINE GUNS OR 20mm CANNONS THAT REQUIRE THE PILOT TO CLOSE TO AT LEAST 1,000 FEET BEFORE FIRING. THIS MAKES THE INTERCEPTOR PILOT VULNERABLE TO THE GUNS OF THE BOMBER WHILE AVERAGING ONLY 10 - 20% KILL PROBABILITY.

THIS YEAR, THE INTERCEPTORS TACTICS WILL CHANGE, DUE TO THE ADVENT OF THE NEW TYPE FIRE CONTROL SYSTEMS AND THE 2.75 AERIAL ROCKET. KILL PROBABILITY SHOULD INCREASE TO 15 - 35%.

IN 1956, WITH THE GUIDED AERIAL ROCKET AS ARMAMENT, THE INTERCEPTOR IS ABLE TO FIRE FROM ANY APPROACH AT A 3 MILE RANGE. WITH A PROPERLY DIRECTED SALVO OF 4 TO 6 MISSILES, THERE IS A 50% KILL PROBABILITY.

WITH THE ADVENT OF NUCLEAR ARMAMENT, THE INTERCEPTOR'S JOB IS MORE SIMPLIFIED. NO DIRECT HITS ARE REQUIRED BUT RATHER MISSES ARE LETHAL FROM THE ATOMIC BURST. THIS TECHNIQUE CAN BE EXPECTED TO PRODUCE 85 - 95% PROBABILITY OF KILL. THE INVESTIGATION OF THE USE OF NUCLEAR ARMAMENT ON FIGHTER INTERCEPTORS HAS BEEN UNDER STUDY FOR SOME MONTHS.

39

~~SECRET~~~~SECURITY INFORMATION~~

AIR DEFENSE COMMAND

~~SECRET~~

INTERCEPTOR ARMAMENT CAPABILITIES

1952

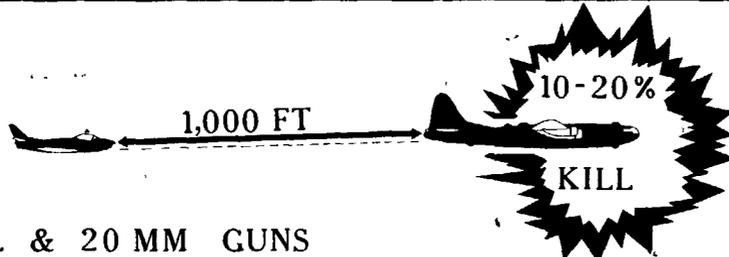

1,000 FT

10-20%
KILL

50 CAL & 20 MM GUNS

1953

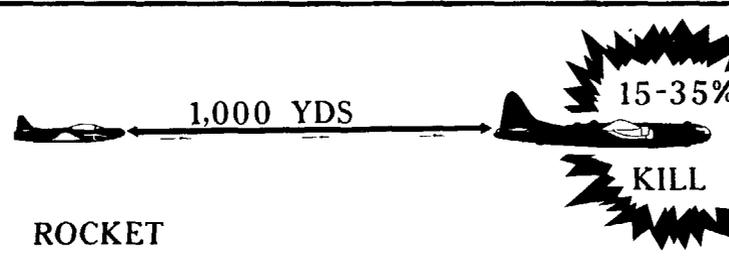

1,000 YDS

15-35%
KILL

2.75 IN ROCKET

1956

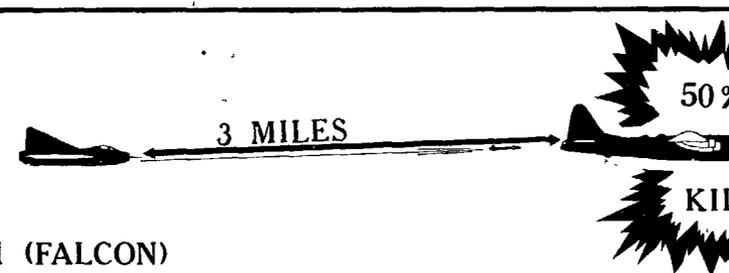

3 MILES

50%
KILL

GAR 1 (FALCON)

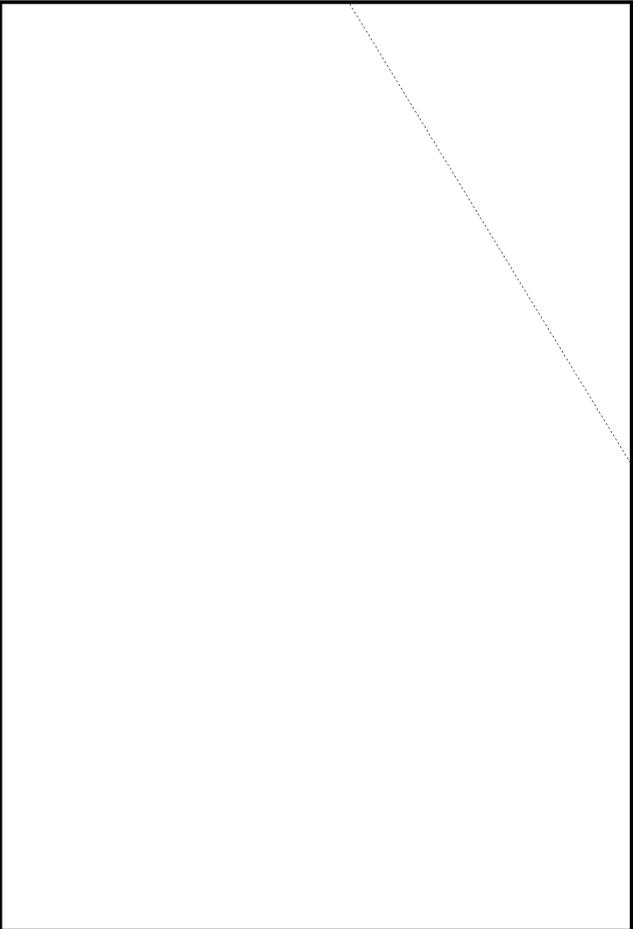

~~SECRET~~

~~SECURITY INFORMATION~~~~SECRET~~PROGRAMMED ANTI-AIRCRAFT DEFENSES

THE ARMY AA COMMAND IS PROGRAMMED TO HAVE 66 BATTALIONS BY 1955 WHICH WILL DEFEND 23 CRITICAL LOCALITIES WITHIN THE UNITED STATES. YOU WILL NOTICE THAT THREE GENERAL TYPES OF TARGETS ARE INCLUDED: POPULATION-INDUSTRIAL AREAS, STRATEGIC AIR COMMAND BASES, AND ATOMIC INSTALLATIONS. THE HEAVIEST CONCENTRATION OF ANTI-AIRCRAFT -- 10 BATTALIONS -- IS AROUND NEW YORK CITY. NEXT IS WASHINGTON WITH SIX; THEN CHICAGO WITH FIVE. OTHER CITIES HAVE EITHER THREE OR FOUR BATTALIONS PLANNED. SEVEN SAC BASES AND THE SOO LOCKS EACH WILL HAVE A SKYSWEEPER BATTALION. THE HANFORD ATOMIC INSTALLATION WILL HAVE FOUR BATTALIONS AND SANDIA-KIRTLAND WILL BE DEFENDED, IN AN EMERGENCY, BY ALL AA BATTALIONS LOCATED AT FORT BLISS, TEXAS.

YOU WILL NOTICE THAT MANY LARGE CITIES DO NOT HAVE ANTI-AIRCRAFT DEFENSES AT THE PRESENT TIME. THE ARMY -- LIKE THE AIR FORCE -- CAN STRETCH A DEFENSE DOLLAR ONLY SO FAR. EVEN SO, THE AA COMMAND IS PLANNING FOR THE EMERGENCY USE OF 90 NATIONAL GUARD BATTALIONS WHICH WILL BE USED TO STRENGTHEN ACTIVE DEFENSES AND TO ESTABLISH ADDITIONAL DEFENSES. WHEN THIS PROGRAM IS FULLY IMPLEMENTED, MOST OF THESE BATTALIONS CAN BE FEDERALIZED AND PLACED ON SITE WITHIN A DAY OR TWO.

40

~~SECRET~~~~SECURITY INFORMATION~~

~~SECRET~~

ANTI AIRCRAFT ARTILLERY DEPLOYMENT

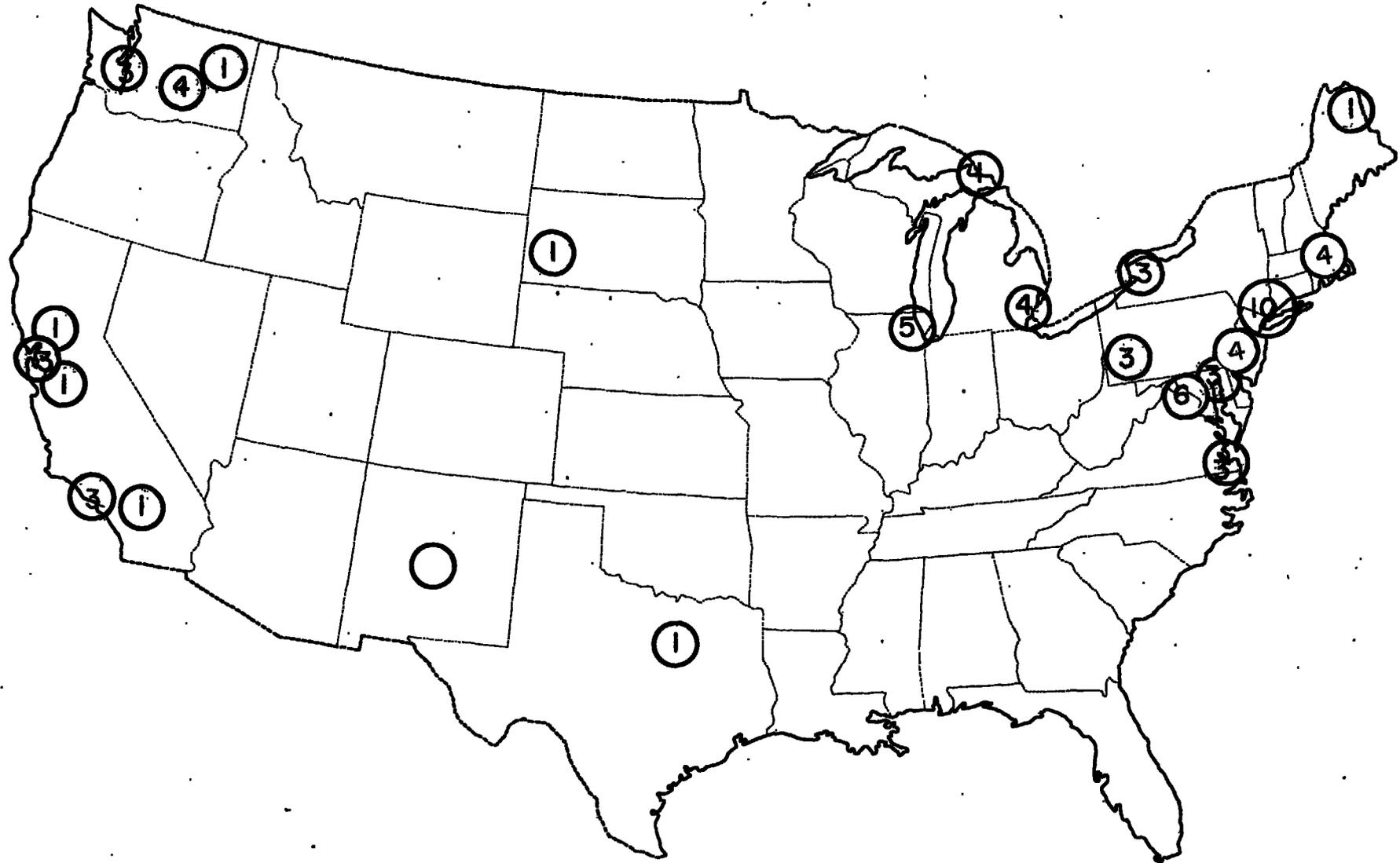

~~SECRET~~

~~SECURITY INFORMATION~~~~SECRET~~PRESENT ANTI-AIRCRAFT DEFENSES

HERE WE SEE THE PRESENT DEPLOYMENT OF THE 57 BATTALIONS THAT ARE CURRENTLY ASSIGNED TO THE AA COMMAND. ALL BUT THREE OF THESE BATTALIONS ARE LOCATED ON-SITE AND ARE READY TO FIRE. THE FOUR BATTALIONS NOT YET ON SITE ARE INDICATED BY SMALL DOTS OUTSIDE OF THE LARGER CIRCLES (3 IN CALIFORNIA, 1 IN WASHINGTON). GETTING THE GUNS LOCATED TO DELIVER EFFECTIVE FIRE HAS BEEN A MAJOR PROBLEM DURING THE PAST TWO YEARS. FIRST, REAL ESTATE HAD TO BE BOUGHT OR LEASED. THIS HAS BEEN DONE. THEN, HOUSING AT THE BATTERY POSITIONS WAS NECESSARY IF TROOPS WERE TO LIVE THERE ALL THE TIME. ADEQUATE FUNDS WERE NOT AVAILABLE, BUT MANY OF THE BATTALIONS MOVED ON SITE AND LIVED IN TENTS FOR MANY MONTHS. PREFABRICATED HUTMENTS WERE OBTAINED SEVERAL MONTHS AGO, AND WITH THE SOLDIERS THEMSELVES DOING THE LABOR, THESE WERE ERECTED WITH A GREAT IMPROVEMENT IN LIVING CONDITIONS. THESE CONDITIONS ARE STILL SUB-STANDARD FOR PERMANENT LIVING BUT ARE NECESSARY IN ORDER FOR ANTI-AIRCRAFT TO FIRE AT ANY "UNKNOWN" TIME.

41

~~SECRET~~~~SECURITY INFORMATION~~

~~SECURITY INFORMATION~~~~SECRET~~NIKE

IN A FEW MONTHS, THE ARMY ANTI-AIRCRAFT COMMAND WILL BEGIN ADDING GUIDED MISSILES TO MANY OF ITS DEFENSES. THIS MISSILE, THE "NIKE", WILL BE EFFECTIVE UP TO 60,000 FEET ALTITUDE AND OUT TO 25 MILES IN RANGE. THUS, THEY WILL COVER A MUCH GREATER AREA THAN THAT OF GUNS. THE "NIKE", WHICH IS NOW GOING INTO FULL PRODUCTION, HAS BEEN VERY SUCCESSFUL IN TEST FIRINGS AT WHITE SANDS PROVING GROUNDS, NEW MEXICO. SEVERAL RADIO-CONTROLLED B-17s HAVE BEEN COMPLETELY DESTROYED BY THE "NIKE"; THESE DRONE B-17s WERE AT ALTITUDES UP TO 30,000 FEET AND AT RANGES UP TO 18 MILES. BY THE FALL OF 1954, 28 NIKE BATTALIONS SHOULD BE OPERATIONAL AND ON-SITE AT 12 CRITICAL AREAS. A SUBSEQUENT INCREASE IN NIKE UNITS WILL RESULT IN AN INCREASE IN THE NUMBER OF MISSILE DEFENSES.

42

~~SECRET~~~~SECURITY INFORMATION~~

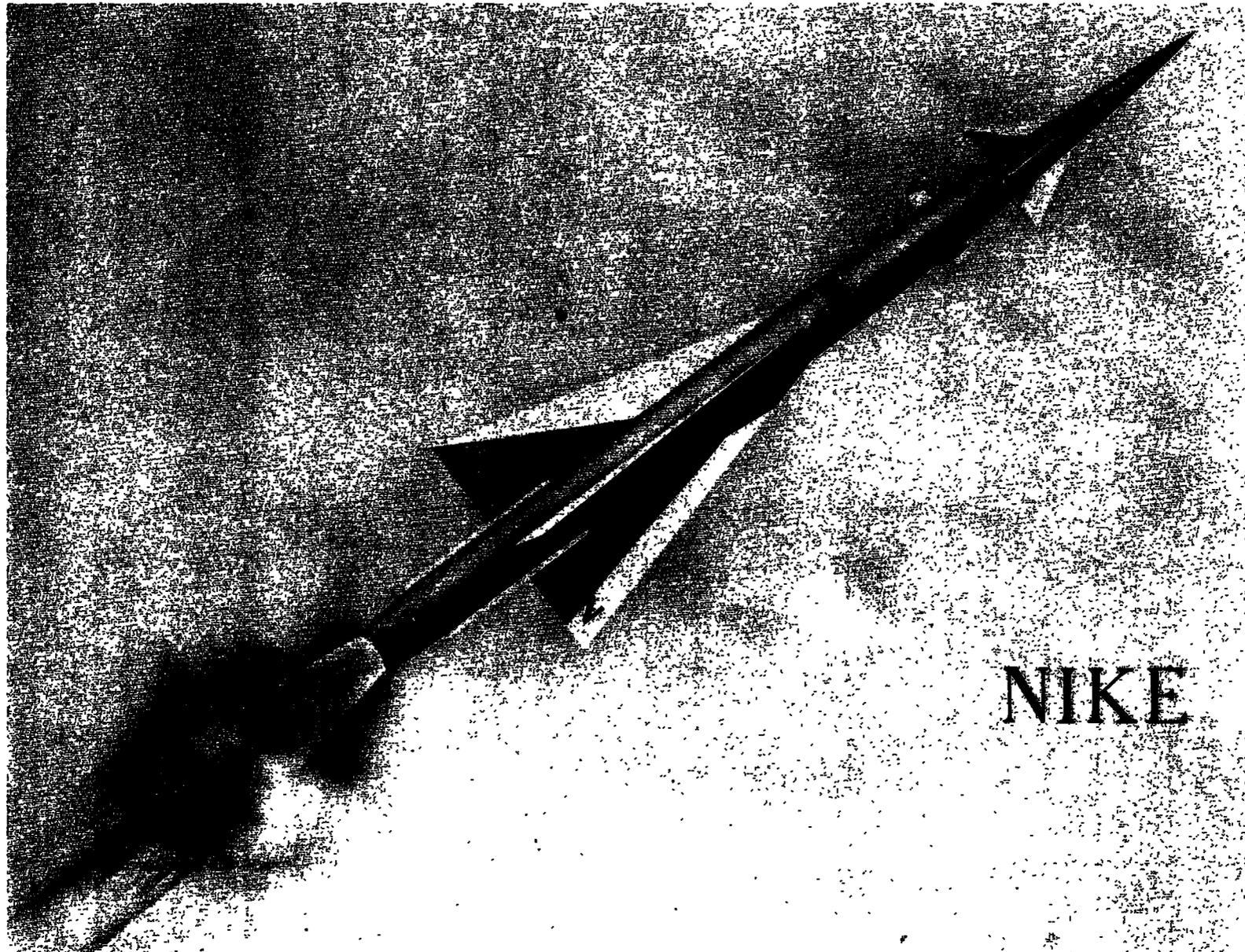

NIKE

~~SECURITY INFORMATION~~~~SECRET~~ELECTRONIC COUNTERMEASURES

ELECTRONIC COUNTERMEASURES AND THEIR EFFECTIVE EMPLOYMENT HAVE A VITAL PLACE IN THE AIR DEFENSE PROGRAM. THIS INCLUDES ACTIVE ECM, PASSIVE ECM, AND ECM TRAINING.

THE PASSIVE AND TRAINING ASPECTS OF THE ECM PROGRAM INCLUDE PASSIVE DETECTION AND ANTI-JAMMING. ANTI-JAMMING TECHNIQUES AND PROCEDURES HAVE BEEN DEVELOPED FOR BOTH RADAR AND COMMUNICATIONS EQUIPMENT. A CONTINUING ANTI-JAMMING TRAINING PROGRAM IS BEING CONDUCTED TO MAINTAIN THE PROFICIENCY OF OPERATING AND MAINTENANCE PERSONNEL.

ACTIVE ECM CONSISTS OF JAMMING OF ENEMY ELECTRONIC EQUIPMENT. THE RESEARCH AND DEVELOPMENT PHASE OF THE GROUND JAMMER PROGRAM WAS TURNED OVER TO THE SIGNAL CORPS. TO PREVENT POSSIBLE INDISCRIMINATE AND UNCOORDINATED JAMMING, WHICH COULD NULLIFY OUR ENTIRE AIR DEFENSE SYSTEM, IT IS OBVIOUS THAT THE USE OF ALL GROUND BASED JAMMING EQUIPMENT IN THE ZI MUST BE INTEGRATED INTO THE AIR DEFENSE SYSTEM.

A DEFINITE STATEMENT OF OUR REQUIREMENTS CANNOT BE MADE UNTIL THE FEASIBILITY OF THIS EQUIPMENT HAS BEEN DEMONSTRATED BY OPERATIONAL TESTS. BASED UPON PRESENT KNOWLEDGE, POINT DEFENSE OF VITAL TARGETS APPEARS TO BE THE MOST PRACTICAL APPLICATION OF GROUND BASED JAMMERS. OUR DESIRE, HOWEVER, IS TO OBTAIN AN AREA JAMMING CAPABILITY. THE GOAL IS TO DESTROY ALL DETECTED HOSTILES BY ACTIVE MEANS. IDEALLY, WE WOULD DENY THE UNDETECTED HOSTILES ALL USE OF HIS NAVIGATIONAL AND BOMBING RADAR BY JAMMING.

43

~~SECRET~~~~SECURITY INFORMATION~~

~~RESTRICTED SECURITY INFORMATION~~

ELECTRONIC COUNTER MEASURES

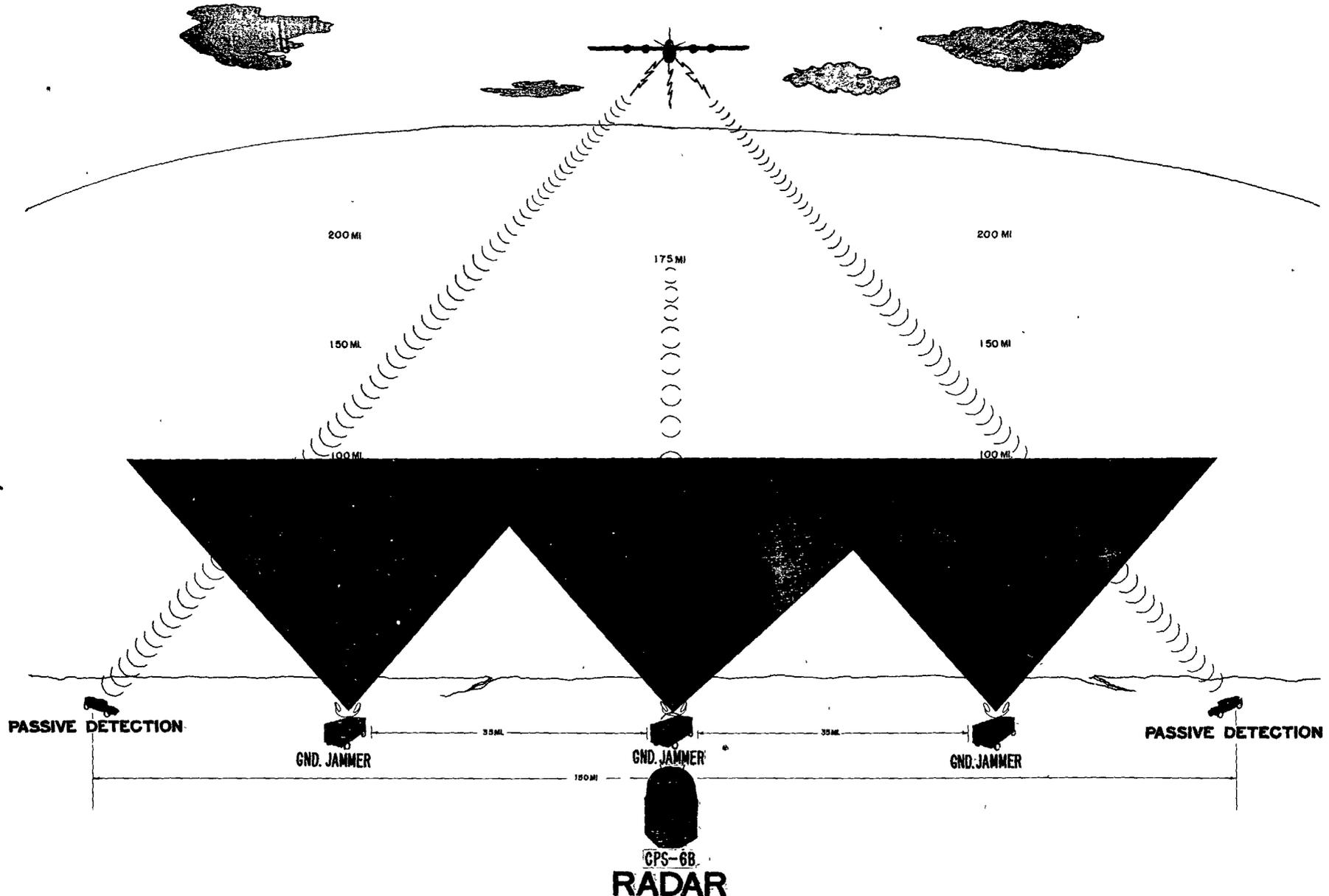

~~RESTRICTED SECURITY INFORMATION~~

~~SECURITY INFORMATION~~~~SECRET~~DECENTRALIZATION OF CONTROL

THIS CHART SHOWS THE LOCATION OF ADC HEADQUARTERS - BY ¹SOLID STARS THE THREE AIR DEFENSE FORCE HEADQUARTERS AND BY HEAVY BLACK LINES THE AIR DEFENSE FORCE BOUNDARIES, BY BLACK SQUARES THE 11 AIR DIVISION HEADQUARTERS. THE DIVISION SECTORS ARE SHOWN BY NARROW BLACK LINES. CIRCLES INDICATE RADAR STATIONS.

THE AIR DEFENSE COMMAND CONCEPT OF OPERATIONS AT PRESENT IS "DECENTRALIZATION OF CONTROL". THE VERY NATURE OF OUR ASSIGNED MISSION, THAT OF PROVIDING AN ADEQUATE AIR DEFENSE AT ANY UNKNOWN TIME, DICTATES THIS POLICY. DECISIONS SUCH AS SCRAMBLING FIGHTERS, CONTROLLING AIR TRAFFIC, ESTABLISHING CONDITIONS OF ALERT, MUST BE MADE QUICKLY; THE TIME FACTOR INVOLVED IS ALL IMPORTANT AND MAY MEAN THE DIFFERENCE BETWEEN SUCCESS OR FAILURE IN AIR DEFENSE. FOR EXAMPLE, THE DIRECTION CENTER CONTROLLER CANNOT WAIT FOR AIR DIVISION PERMISSION TO SCRAMBLE FIGHTERS. AIR DIVISION CANNOT WAIT FOR AIR DEFENSE FORCE PERMISSION TO ESTABLISH CONDITIONS OF WARNING; AIR DEFENSE FORCE CANNOT WAIT FOR HEADQUARTERS ADC TO DECLARE ACTION AS MANIFESTLY HOSTILE IN INTENT. THESE IMPORTANT DECISIONS MUST BE MADE PROMPTLY BY THE COMMANDER ON THE SPOT; HE ALONE HAS FIRST HAND INFORMATION ON EACH SPECIFIC INCIDENT, AND MUST TAKE APPROPRIATE ACTION IMMEDIATELY.

THIS IS NOT THE MOST EFFECTIVE METHOD OF PROPER THREAT EVALUATION AND WEAPON ASSIGNMENT, - BUT MUST CONTINUE AS LONG AS WE HAVE MANUAL METHODS OF DATA COLLECTION, HANDLING, AND DISPLAY.

ll

~~SECRET~~~~SECURITY INFORMATION~~

~~SECRET~~ SECURITY INFORMATION

DECENTRALIZATION OF CONTROL

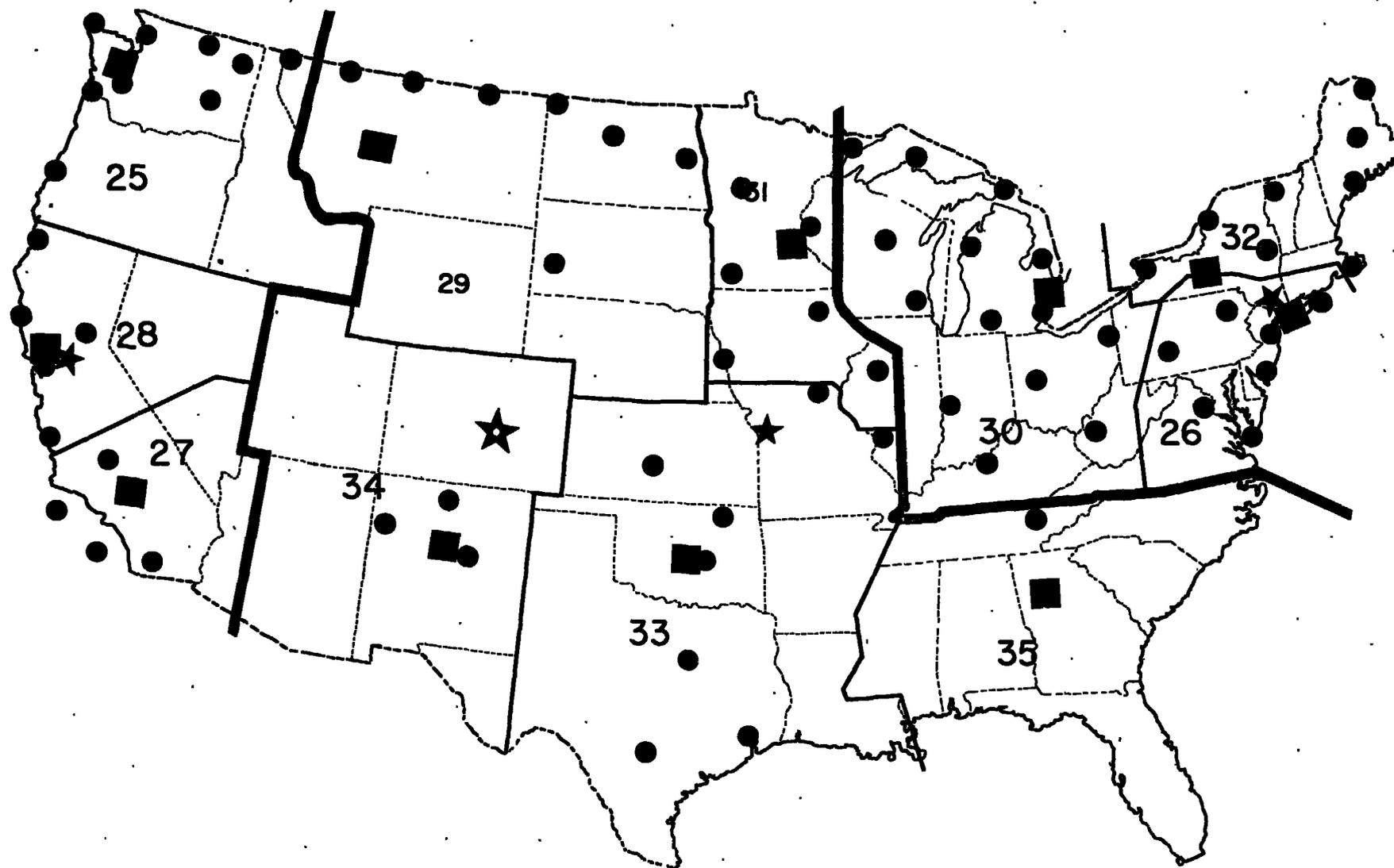

~~SECRET~~ SECURITY INFORMATION

AIR DEFENSE WARNING

THE DIVISION CONTROL CENTER IS RESPONSIBLE FOR INITIATING WARNINGS. HIGHER HEADQUARTERS CAN ALSO INITIATE WARNINGS. THE DEGREE OF WARNING IS INDICATED BY ONE OF FOUR CONDITIONS OF ALERT. WARNING RED -- MEANS THAT ATTACK IS IMMINENT OR UNDERWAY, AND IS ANNOUNCED OVER ALL WARNING SYSTEMS AND BY CIVIL OFFICIALS TO THE GENERAL PUBLIC. WARNING YELLOW -- MEANS THAT ATTACK IS LIKELY, AND IS ANNOUNCED OVER THE WARNING SYSTEMS BUT NOT TO THE GENERAL PUBLIC. WARNING WHITE -- MEANS "ALL CLEAR" TO THE GENERAL PUBLIC BUT A MILITARY EMERGENCY EXISTS AND EMERGENCY AIR TRAFFIC CONTROLS ARE IN EFFECT.

THIS ALERT SYSTEM IS DESIGNED TO KEEP US ON OUR TOES AND ISSUE TIMELY WARNINGS; BUT YET, BY TAKING A CALCULATED RISK, AVOID UNDUE DISRUPTION OF NORMAL CIVIL ACTIVITIES.

THE FOURTH CONDITION, APPLYING ONLY TO THE ACTIVE AIR DEFENSE UNITS, IS CALLED "AIR DEFENSE READINESS", WHICH MEANS THAT INTELLIGENCE INFORMATION AND/OR SUSPICIOUS PATTERNS OF UNIDENTIFIED AIRCRAFT INDICATE AN INCREASED POSSIBILITY OF AN ATTACK. THIS CONDITION IS DISSEMINATED ONLY TO THE MILITARY AND IS A MEANS OF PLACING THE AIR DEFENSE SYSTEM IN AN ADVANCED STATE OF PREPAREDNESS WITHOUT UNNECESSARILY DISRUPTING ACTIVITIES.

AIR DEFENSE WARNINGS

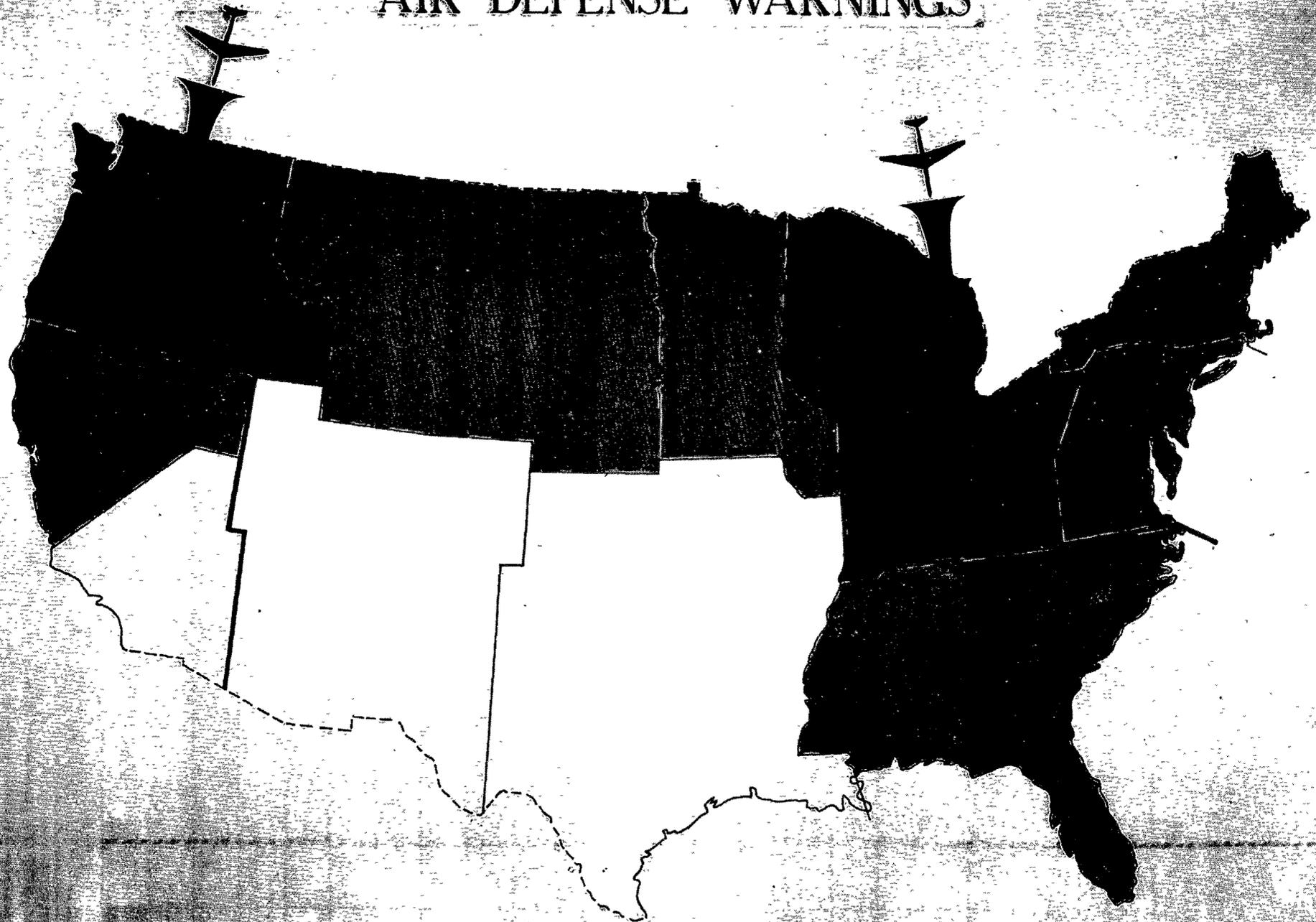

CIVIL AIR DEFENSE WARNING

CONDITION OF AIR DEFENSE WARNING, AS DETERMINED BY THE APPROPRIATE AIR FORCE COMMANDER, IS PASSED OVER THE SPECIAL AIR DEFENSE WARNING NET, SIMULTANEOUSLY, TO ALL CIVIL, KEY POINT, AIR DEFENSE WARNING CENTERS, WITHIN THE AIR DIVISION AREA. EVERY STATE HAS ONE OR MORE KEY POINTS. THE AIR FORCE IN NO WAY PRESCRIBES ANY RESTRICTION, ON THE RECEIVING CIVIL AUTHORITIES, AS TO THE DISSEMINATION OR USE MADE, OF THE AIR DEFENSE WARNINGS RECEIVED BY THE KEY POINTS.

THE FEDERAL CIVIL DEFENSE ADMINISTRATION HAS LIAISON PERSONNEL AT OUR AIR DIVISION HEADQUARTERS. ONE OF THEIR FUNCTIONS IS OPERATIONAL CONTROL OF THE CIVIL AIR DEFENSE WARNING SYSTEM. THE AIR DIVISION ADVISES THE FCDA REPRESENTATIVE OF THE CONDITION OF AIR DEFENSE WARNING. THE RESPONSIBILITY FOR DISSEMINATION FROM THE AIR DEFENSE CONTROL CENTER, TO THE PUBLIC, THEN RESTS ENTIRELY WITH CIVIL AUTHORITY.

THE MILITARY AIR DEFENSE WARNING NET IS ESTABLISHED IN A SIMILAR MANNER BUT IS OPERATED ENTIRELY BY MILITARY PERSONNEL.

CIVIL AIR DEFENSE WARNING

2025 RELEASE UNDER E.O. 14176

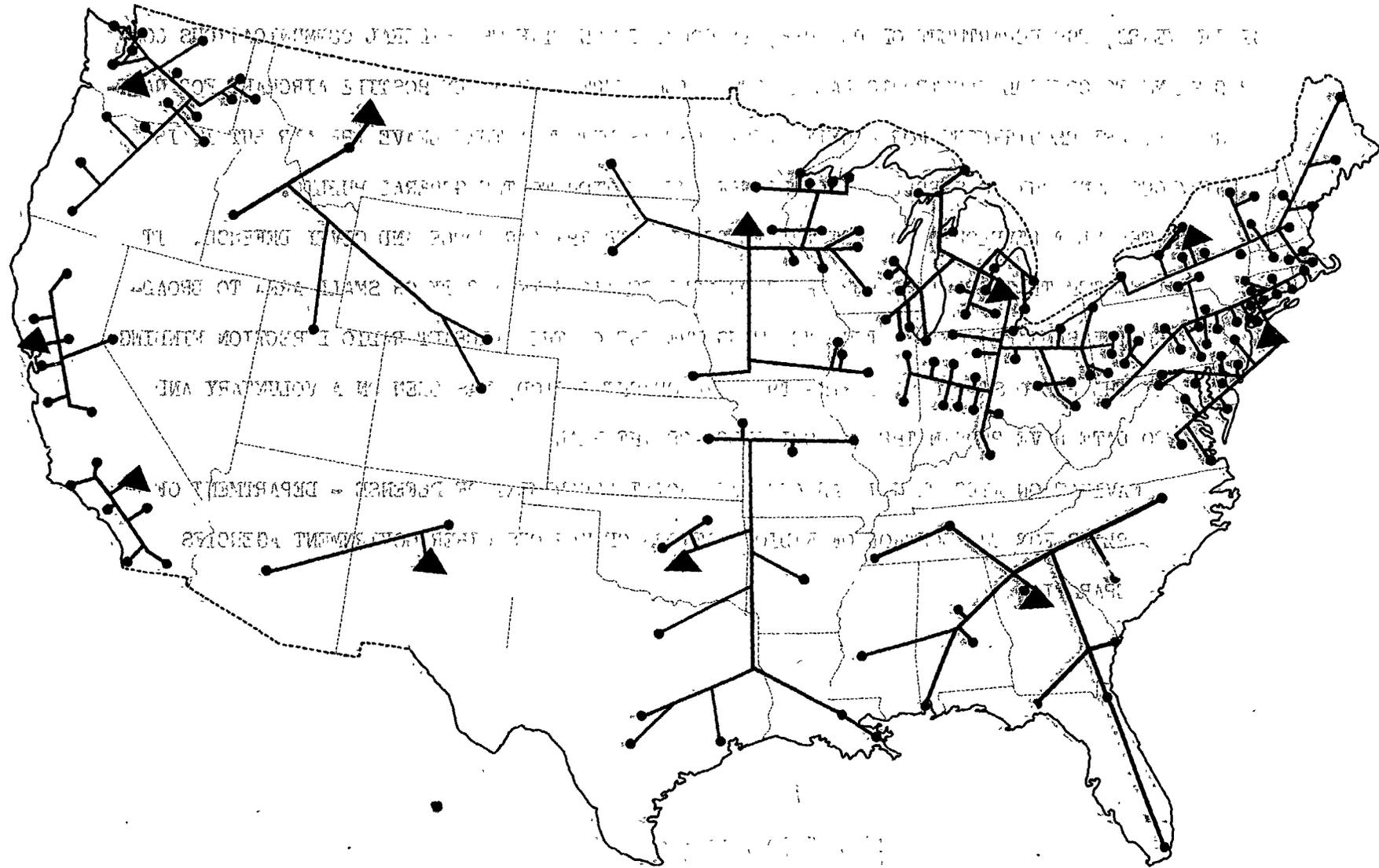

~~SECURITY INFORMATION~~**RESTRICTED**CONTROL OF ELECTROMAGNETIC RADIATIONS

DURING THE PAST TWO YEARS, THE DEPARTMENT OF DEFENSE, IN CONJUNCTION WITH THE FEDERAL COMMUNICATIONS COMMISSION, HAS DEVELOPED PLANS TO CONTROL ELECTRONIC FACILITIES WHICH MIGHT BE USED BY HOSTILE AIRCRAFT FOR NAVIGATIONAL PURPOSES. THE MILITARY REQUIREMENT FOR DENYING THEIR USE IS MET WHEN THEY LEAVE THE AIR BUT IT IS ESSENTIAL THAT THEIR SERVICES CONTINUE TO SUPPLY CIVIL DEFENSE INFORMATION TO THE GENERAL PUBLIC.

THIS CHART REPRESENTS THE PLAN DEVELOPED TO MEET THE NEEDS OF BOTH THE AIR FORCE AND CIVIL DEFENSE. IT IS A SYNCHRONOUS-SEQUENTIAL SYSTEM THAT PROVIDES FOR THREE OR MORE STATIONS IN A CITY OR SMALL AREA TO BROADCAST IN A VARIED SEQUENCE ON THE SAME FREQUENCY; THUS NEGATING THE USE OF THE AIRCRAFT RADIO DIRECTION FINDING EQUIPMENT. PARTICIPATION BY THE RADIO STATIONS, DURING THE DEVELOPMENT PERIOD, HAS BEEN ON A VOLUNTARY AND COOPERATIVE BASIS. TESTS TO DATE HAVE PROVEN THE EFFECTIVENESS OF THE PLAN.

FOR THE CONTROL OF AIR NAVIGATION AIDS WE HAVE AN APPROVED JOINT DEPARTMENT OF DEFENSE - DEPARTMENT OF COMMERCE PLAN. IN ADDITION, PLANS FOR THE CONTROL OF RADIO STATIONS OF VARIOUS OTHER GOVERNMENT AGENCIES ARE NOW IN FINAL STAGES OF PREPARATION.

47

RESTRICTED~~SECURITY INFORMATION~~

BASIC PLAN - CONELRAD

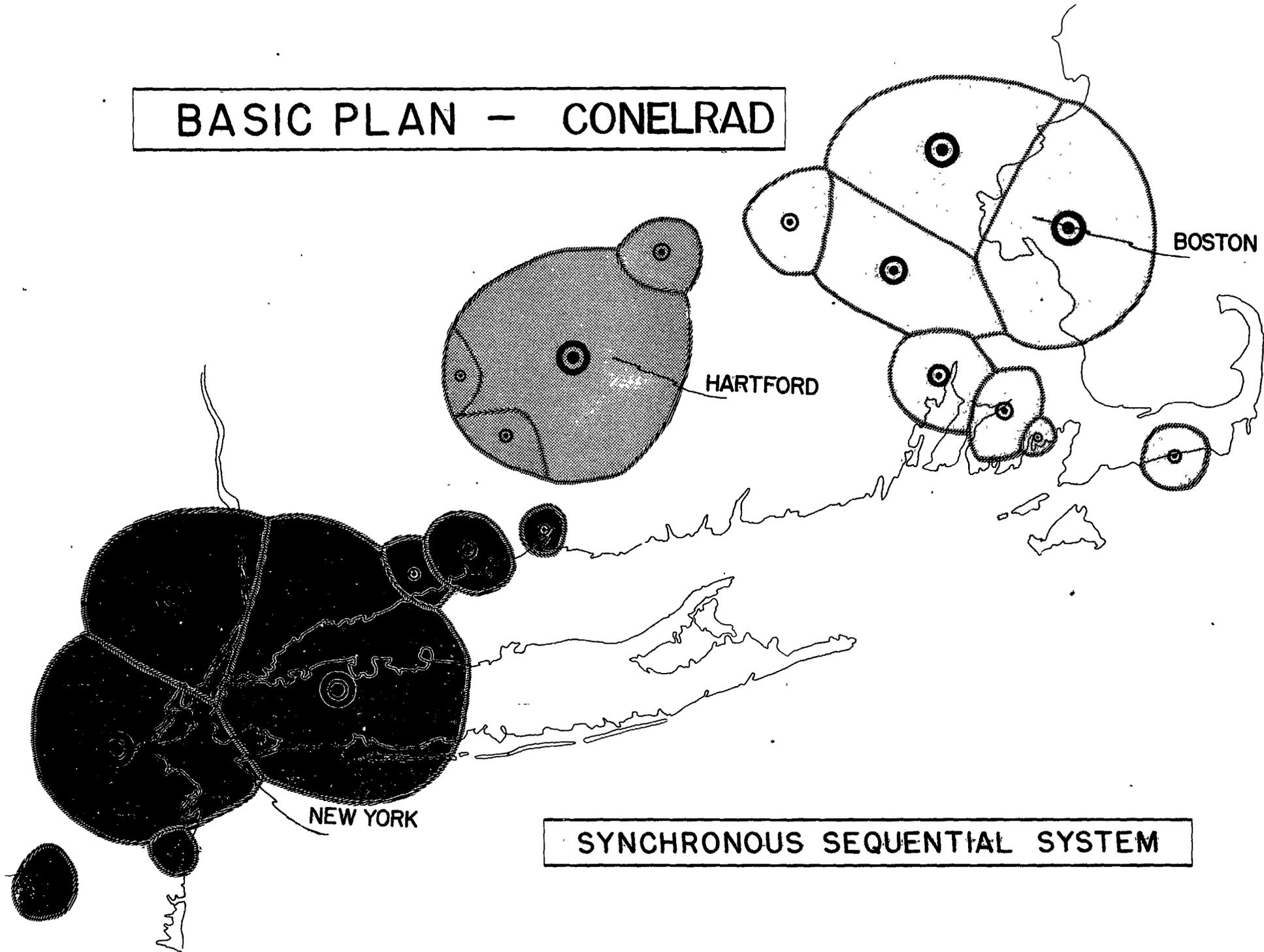

~~SECURITY INFORMATION~~~~SECRET~~WIRE I

THE BACKBONE OF AIR DEFENSE IS THE COMMUNICATION NETWORK REQUIRED TO INTEGRATE THE VARIOUS ACTIVITIES INTO AN EFFICIENT AND COORDINATED SYSTEM.

THIS CHART SHOWS HOW THE VARIOUS ELEMENTS OF THE SYSTEM ARE TIED TOGETHER. WE MUST HAVE A RAPID MEANS OF COMMUNICATIONS FOR:

- A. GATHERING INFORMATION SUPPLIED BY RADARS AND GROUND OBSERVER POSTS.
- B. PERFORMING IDENTIFICATION.
- C. FOR THE STATUS AND CONTROL OF WEAPONS.
- D. FOR PASSING INTELLIGENCE DATA BETWEEN VARIOUS LEVELS OF COMMAND.
- E. AND FOR GIVING TIMELY AIR DEFENSE WARNING TO THE NATION AND THE CONTROL OF ELECTROMAGNETIC RADIATION.

18

18

~~SECRET~~~~SECURITY INFORMATION~~

COMMUNICATION NETWORK

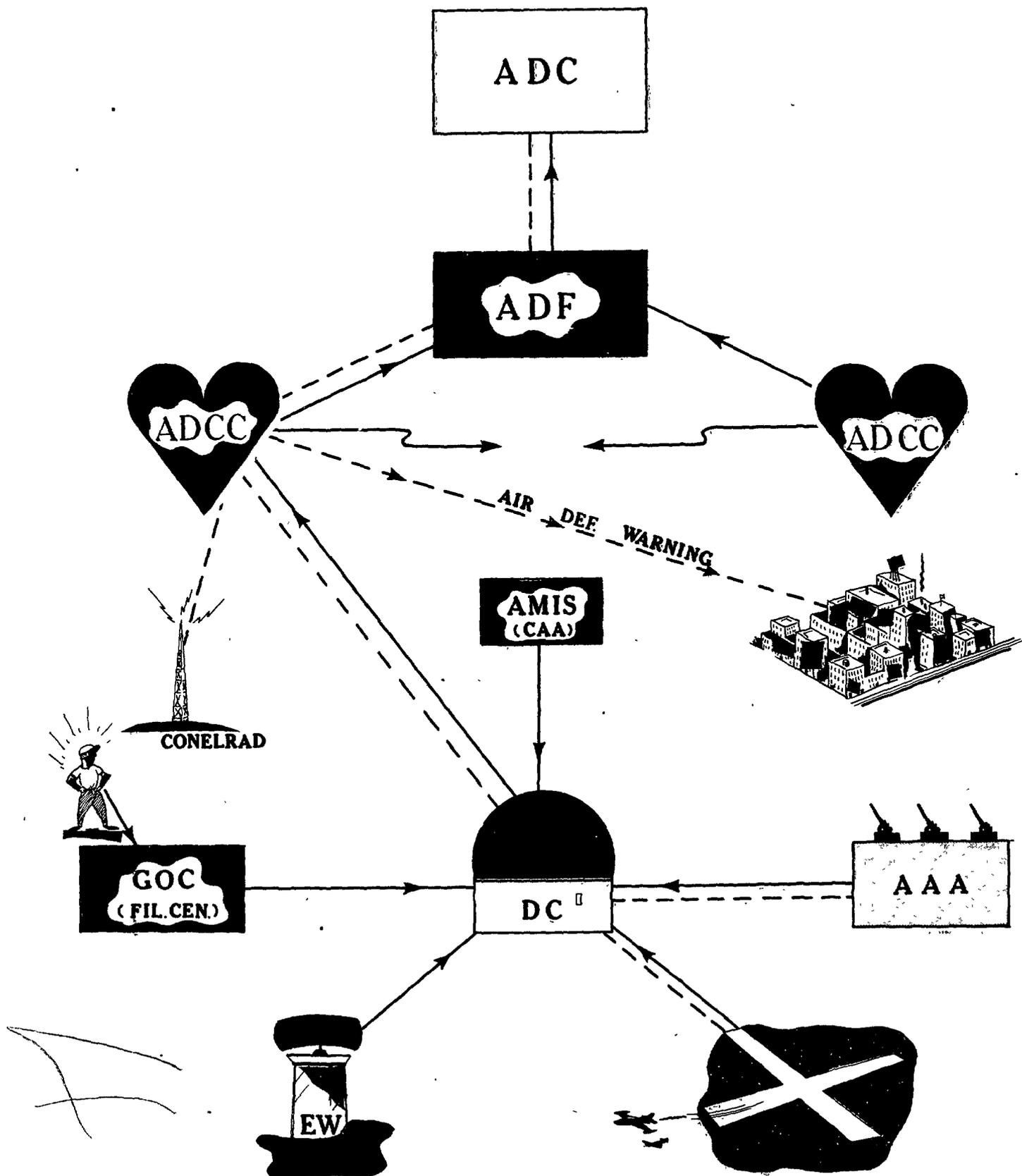

~~SECRET~~

WIRE II

THIS NEXT CHART WILL GIVE YOU SOME IDEA AS TO THE VASTNESS OF COMMUNICATIONS REQUIRED BETWEEN THE VARIOUS ACTIVITIES. WE PRESENTLY HAVE 3 DEFENSE FORCES, 11 COMBAT CENTERS, 79 RADAR STATIONS, 20 ANTI-AIRCRAFT OPERATION CENTERS, 64 FIGHTER BASES, 261 AIR DEFENSE WARNING POINTS, ABOUT 2200 GROUND OBSERVER POSTS AND OVER 300 RADIO STATIONS PARTICIPATING IN THE CONEL-RAD PROGRAM.

AT PRESENT WE ARE LEASING FROM THE TELEPHONE AND TELEGRAPH COMPANIES ABOUT 130,000 MILES OF FULL PERIOD VOICE AND TELETYPE CIRCUITS, AT A YEARLY COST OF ABOUT \$6,500,000. IN ADDITION, THE COMMUNICATION CIRCUITS AND LONG DISTANCE FLASH CALLS MADE BY THE GROUND OBSERVER CORPS COST ABOUT \$3.5 MILLION PER YEAR. OR FOR A COMBINED TOTAL OF ABOUT \$10,000,000 PER YEAR FOR LEASED COMMUNICATION SERVICE.

WHEN ALL OF THE PRESENTLY APPROVED PROGRAM IS COMPLETED, WE WILL BE LEASING ENOUGH CIRCUITS TO REACH THE MOON AND CIRCLE IT 12 TIMES.

NEEDLESS TO SAY, MODERN WARFARE DICTATES THAT WE BE PREPARED TO DEFEND OURSELVES WITHOUT THE BENEFIT OF ADVANCED WARNING; A FEW MINUTES MAY SPELL THE DIFFERENCE BETWEEN SUCCESS AND DEFEAT. I WISH TO EMPHASIZE THAT AN EFFICIENT COMMUNICATION SYSTEM IN BEING IS ESSENTIAL TO AN EFFECTIVE AIR DEFENSE.

49

~~SECRET~~

SECURITY INFORMATION

AIR DEFENSE SYSTEM STANDARD WIRE NETWORK

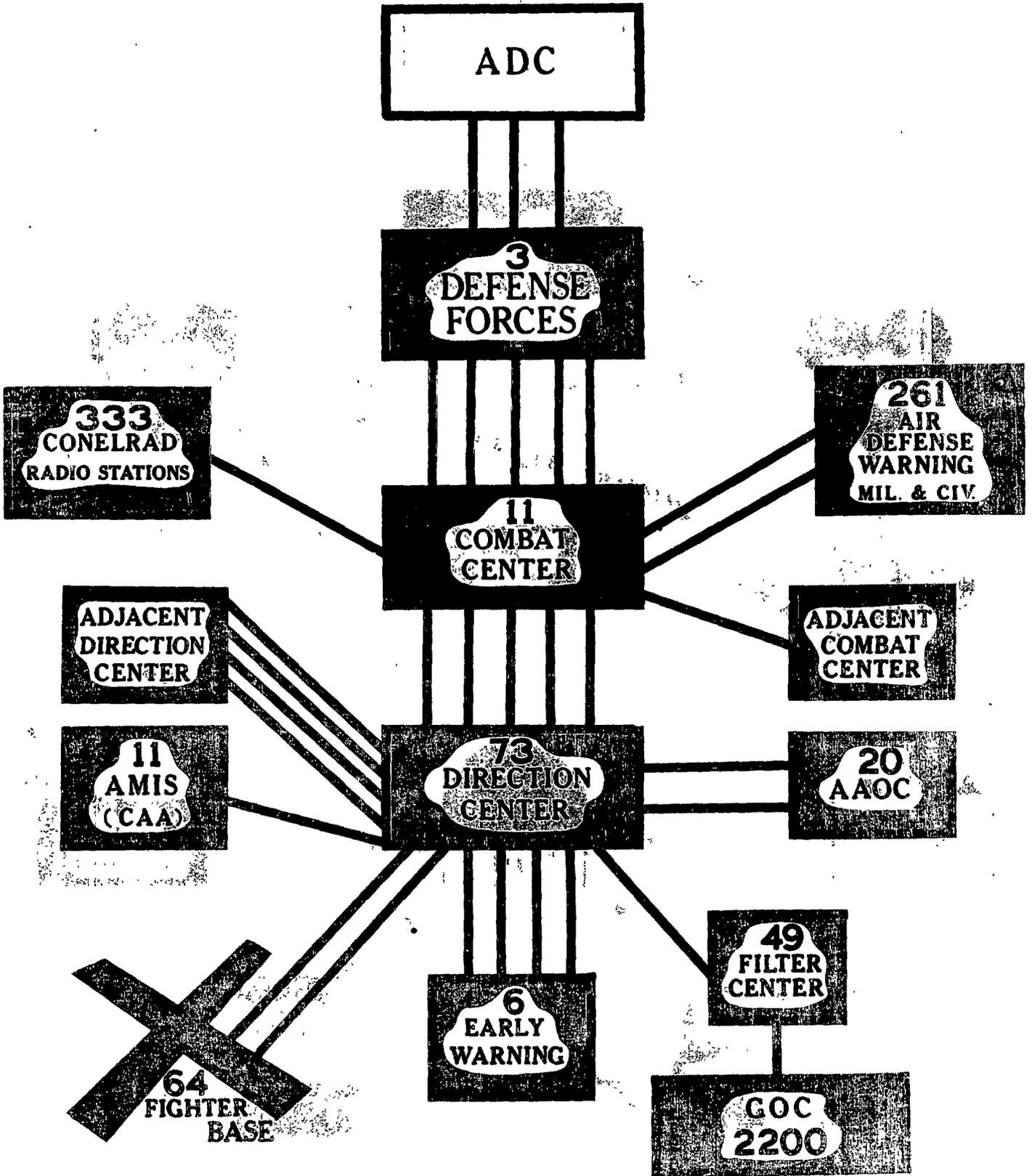

WEATHER IN AIR DEFENSE

WEATHER SUPPORT IS PROVIDED TO ALL ECHELONS OF THE AIR DEFENSE COMMAND BY THE 3RD WEATHER GROUP. THIS IS A UNIT OF THE MATS AIR WEATHER SERVICE AND SERVES AS AN INTEGRAL PART OF THE AIR WEATHER SERVICE GLOBAL METEOROLOGICAL NETWORK.

THE ORGANIZATION OF THE 3RD WEATHER GROUP PARALLELS THAT OF THE AIR DEFENSE COMMAND THROUGH ALL ECHELONS DOWN TO THE FIGHTER INTERCEPTOR BASE LEVEL. WEATHER GROUP, SQUADRON AND DETACHMENT COMMANDERS ARE AVAILABLE FOR DUTIES AS STAFF WEATHER OFFICERS AT ALL WEATHER ECHELONS.

THE WEATHER SUPPORT PROVIDED IS TAILORED TO THE NEEDS OF THE USING AGENCY. AT HQ AIR DEFENSE COMMAND IS AN AIR DEFENSE WEATHER SERVICE FORECAST CENTER WHICH PROVIDES NORTHERN HEMISPHERE WEATHER FORECASTS, INTELLIGENCE ESTIMATES OF POSSIBLE INVASION ROUTE WEATHER, COMPLETE CLIMATOLOGICAL STUDIES REQUIRED AT AIR DEFENSE COMMAND. AT EACH DIVISION CONTROL CENTER IS A WEATHER UNIT WHICH PROVIDES AREA FORECASTS, FIGHTER BASE FORECASTS, AND BATTLE AREA WEATHER INFORMATION. WEATHER DETACHMENTS AT FIGHTER BASES PROVIDE WEATHER OBSERVATIONS AND INFORMATION NECESSARY FOR THE CONDUCT OF FIGHTER MISSIONS AND RETURN TO BASE.

WEATHER ORGANIZATION

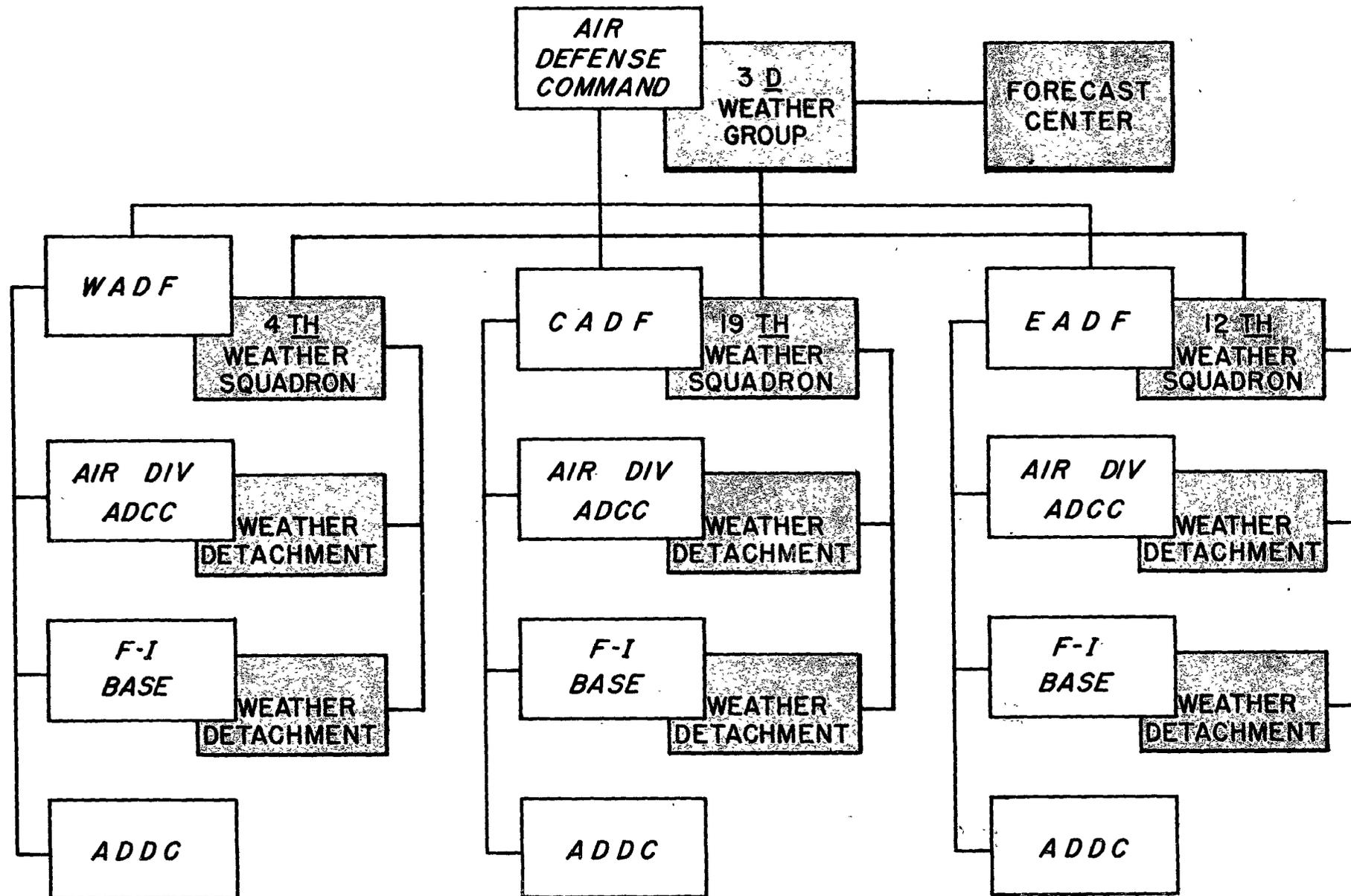

~~SECURITY INFORMATION~~**SECRET**AIR DEFENSE EXERCISES

THE PRESENT PROGRAM FOR AIR DEFENSE TRAINING EXERCISES CALLS FOR TWO COMMAND-WIDE EXERCISES A YEAR. THESE ARE TENTATIVELY PLANNED FOR JULY AND DECEMBER. STRATEGIC AIR COMMAND PROVIDES THE MAJOR AGGRESSOR STRIKE EFFORT, APPROXIMATELY 200 STRIKE AIRCRAFT WILL FLY SIMULATED REALISTIC ATTACK ROUTES AGAINST THE AIR DEFENSE SYSTEM DURING A 48 HOUR PERIOD.

THE PRIMARY OBJECTIVE OF THESE EXERCISES IS TO PROVIDE REALISTIC TRAINING IN THE EMPLOYMENT OF OUR AIR DEFENSE CAPABILITIES AGAINST REALISTIC TECHNIQUES OF ATTACK. THE SECONDARY OBJECTIVE IS TO TEST AND EVALUATE THE AIR DEFENSE FORCE CAPABILITY IN CONDUCTING THE DEFENSE. THESE EXERCISES WILL PROVIDE TRAINING FOR INTEGRATION AND EMPLOYMENT OF ALL FORCES AND FACILITIES AVAILABLE FOR AIR DEFENSE, TO INCLUDE FACILITIES OF OTHER COMMANDS AND SERVICES AND THE RCAF.

FROM THESE EXERCISES WE RECEIVE INVALUABLE SYSTEMS TRAINING, OPPORTUNITIES TO TEST OPERATIONAL PLANS AND PROCEDURES, EVALUATE POLICY AND DOCTRINE, EMPLOY FORCES HAVING A COROLIARY OR SECONDARY MISSION OF AIR DEFENSE, AND GARNER INFORMATION ABOUT OUR STRENGTHS AS WELL AS OUR WEAKNESSES. GENERALLY SPEAKING, THIS IS AN EVALUATION OF THE OVERALL TRAINING AND OPERATIONAL CAPABILITY OF THE AIR DEFENSE SYSTEM.

ROUTINE TRAINING MISSIONS FLOWN BY SAC UNITS FOR CAMERA GUNNERY TRAINING WILL STILL PROVIDE FOR OUR REQUIRED INDIVIDUAL TRAINING.

51

SECRET~~SECURITY INFORMATION~~

AIR DEFENSE EXERCISES

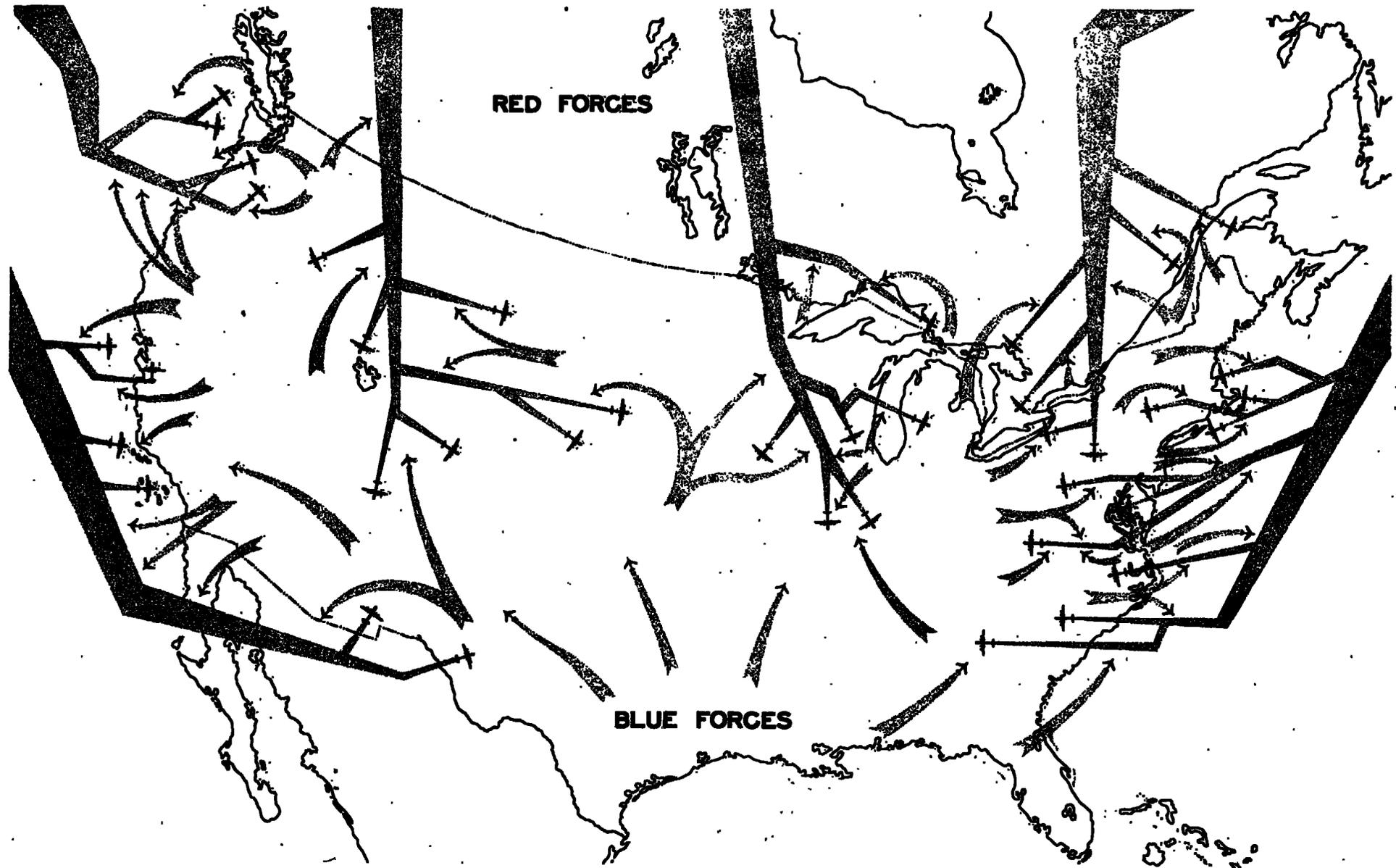

~~SECURITY INFORMATION~~~~SECRET~~OPERATIONAL STATISTICS

THIS CHART IS SIMPLY TO PORTRAY THE CORRELATION AND IDENTIFICATION PROBLEM. HERE ARE SOME HISTORICAL OPERATIONAL STATISTICS. THESE ARE AVERAGE FIGURES TAKEN FROM OPERATIONAL RECORDS.

25,000 FLIGHTS EMANATE DAILY FROM AIR FIELDS WITHIN THE CONTINENTAL UNITED STATES UPON WHICH THERE ARE CAA FACILITIES. THE MAGNITUDE OF THE CORRELATION AND IDENTIFICATION PROBLEM DURING PEACETIME OPERATIONS CAN BE APPRECIATED WHEN IT IS REALIZED THAT 16,000 OF THESE FLIGHTS OCCUR IN CRITICAL AREAS. ADD TO THIS THE NUMBER OF FLIGHTS EMANATING FROM AIR FIELDS WHICH DO NOT HAVE CAA FACILITIES (FOR WHICH THERE ARE FIGURES AVAILABLE). -- DETECTION, TRACKING AND IDENTIFICATION IS ESSENTIAL IN PERIMETER ZONES BEFORE THE ENEMY AIRCRAFT GETS MIXED INTO THE TREMENDOUS AMOUNT OF INTERNAL FRIENDLY AIR TRAFFIC. --

THE AIR DEFENSE COMMAND NOW HAS AN AVERAGE OF 122 FIGHTER AIRCRAFT ON ALL STATES OF ALERT. ON THESE, 60 ARE ON 5 MINUTE ALERT.

AIRCRAFT THAT CANNOT READILY BE IDENTIFIED AS THEY PENETRATE AN AIR DEFENSE AREA ARE TERMED "UNKNOWNNS". THESE AVERAGE 45 PER DAY. STANDARD PRACTICE IS TO SCRAMBLE FIGHTERS TO INTERCEPT THESE "UNKNOWNNS" FOR VISUAL IDENTIFICATION. LACK OF AW FIGHTERS FOR USE IN BAD WEATHER AND NIGHT OPERATIONS LIMITED THIS INTERCEPTION TO A DAILY AVERAGE OF 29.

THE AVERAGE TIME FROM SCRAMBLE ORDER TO AIRBORNE WAS 3.9 MINUTES.

INTERCEPTION TIME AVERAGED 16.5 MINUTES.

TARGET TRAVEL AVERAGED 95.6 NAUTICAL MILES TO INTERCEPTION (BASED ON TARGET SPEED OF 240 KNOTS). THIS IS A CRITICAL FIGURE IN MOST AREAS AND MUST BE REDUCED BY IMPROVEMENTS IN EQUIPMENT, PROCEDURES AND TRAINING.

52

~~SECRET~~~~SECURITY INFORMATION~~

OPERATIONAL STATISTICS

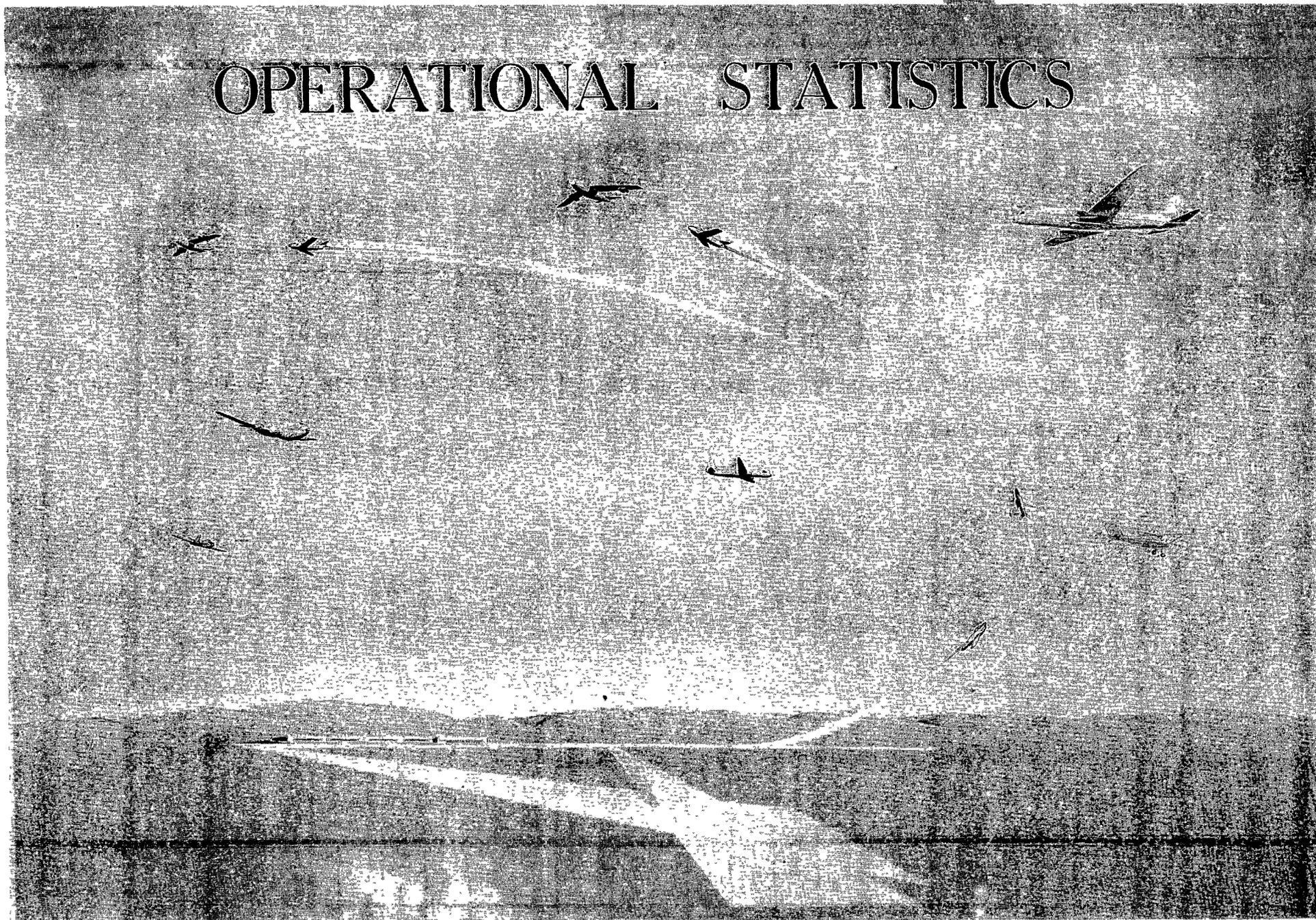

~~SECURITY INFORMATION~~
~~RESTRICTED~~

PRESENT BOUNDARIES

(Eff 16 February 1953)

FOR THE NEXT FEW MOMENTS, I'LL DISCUSS THE AIR DEFENSE SYSTEM THAT IS BEING PLANNED FOR IMPLEMENTATION IN THE 1955-56 PERIOD. OBVIOUSLY, AS THE THREAT INCREASES SO MUST OUR CAPABILITY INCREASE TO MORE ACCURATELY AND RAPIDLY COPE WITH SATURATION TYPE ATTACKS.

THIS CHART IS TO REFRESH YOUR MEMORY ON THE AREAS OF RESPONSIBILITY TODAY. THE WIDE LINES DIVIDE THE AIR DEFENSE FORCE "REGIONS" AND THE NARROW LINES DELINEATE THE AIR DIVISION "SECTORS". THIS SYSTEM HAS THREE AIR DEFENSE FORCES AND 11 AIR DIVISIONS.

53

~~RESTRICTED~~

SECURITY INFORMATION

PRESENT AIR DEFENSE BOUNDARIES

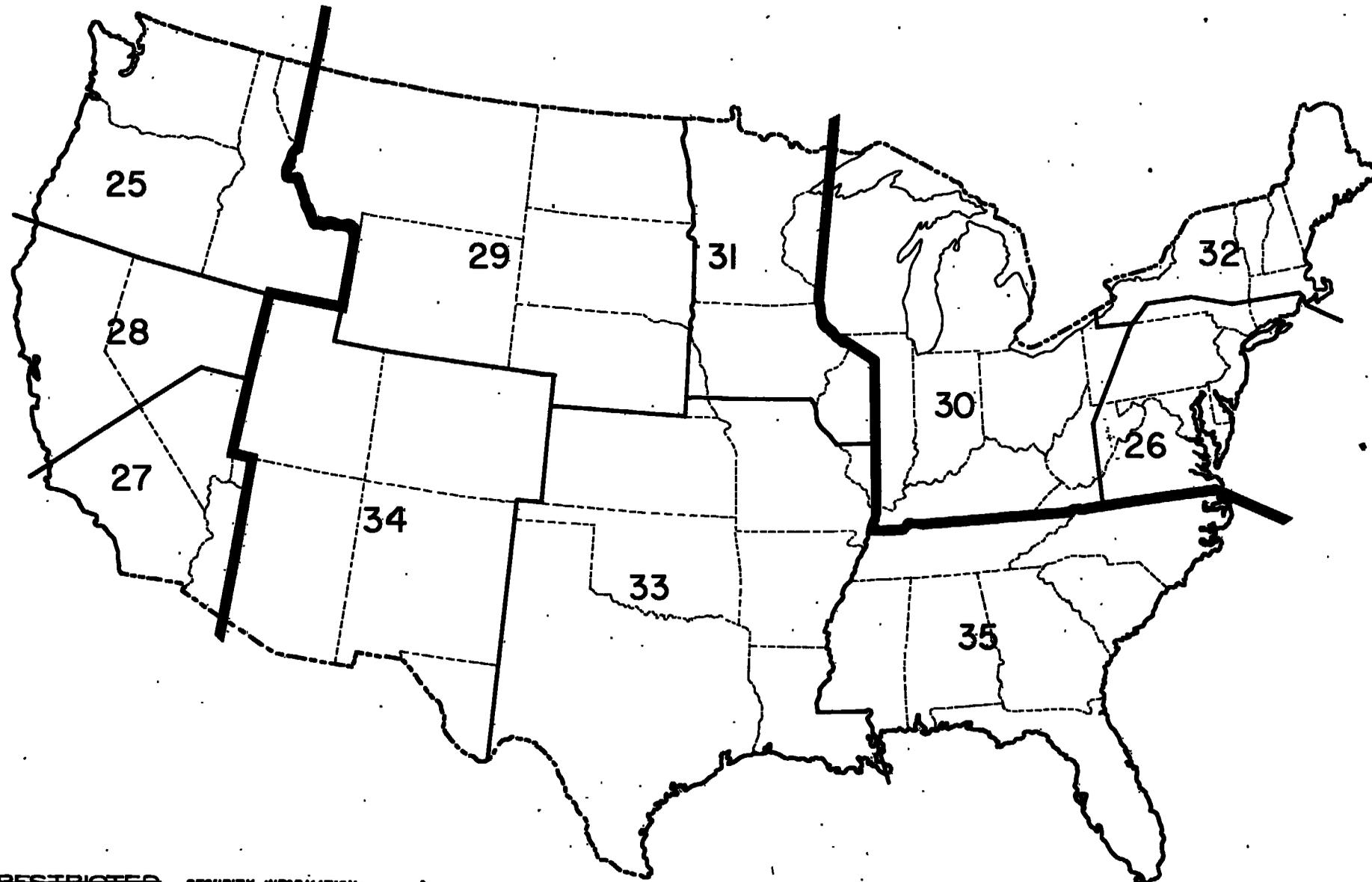

~~SECURITY INFORMATION~~~~SECRET~~1955 BOUNDARIES

SHOWN HERE ARE THE AREAS OF RESPONSIBILITY WE FEEL ARE ESSENTIAL FOR THE 1955 CONCEPT OF OPERATION. WE WILL HAVE THREE AIR DEFENSE FORCE "REGIONS" BUT 18 AIR DIVISION "SECTORS". THE TRIANGLES INDICATE THE AIR DIVISION COMBAT CENTERS, REFERRED TO IN THE PRESENT SYSTEM AS CONTROL CENTERS OR ADCC's. THE SOLID TRIANGLES INDICATE COMBAT CENTERS PRESENTLY OPERATING AS CONTROL CENTERS, AND THE HOLLOW ONES THOSE THAT MUST BE CONSTRUCTED.

THE NEW ALIGNMENT OF DEFENSE FORCES AND DIVISIONS IS TO AFFORD THOSE AREAS OF OUR COUNTRY OF HIGH POPULATION AND HIGH INDUSTRIAL POTENTIAL THE MAXIMUM EFFECTIVENESS IN AN AIR DEFENSE SYSTEM. SUCH A SYSTEM WILL PERMIT THE OPTIMUM EMPLOYMENT OF ALL WEAPONS SUCH AS INTERCEPTORS, LONG-RANGE SURFACE-TO-AIR GUIDED MISSILES, LOCAL DEFENSE GUNS AND MISSILES; AND ANY NEW WEAPONS WE CAN VISUALIZE FOR USE AGAINST MANNED AND UNMANNED AIRCRAFT.

THE AIR DEFENSE FORCE BOUNDARIES RING THE CRITICAL DEFENSE AREAS AND ARE FURTHER SUBDIVIDED INTO SECTIONS ON FOLLOWING CRITERIA: NUMBER AND CHARACTER OF TARGETS IN AREA, TYPE TERRAIN, AVAILABILITY OF WEAPON BASES AND COMMUNICATIONS FACILITIES, RANGE OF WEAPONS, AND THE PROBABLE NUMBER OF AIR BATTLES THAT MAY OCCUR IN ANY ONE AREA.

IN THE 1955 SYSTEM ALL REQUIRED DATA WILL BE FED INTO THE COMBAT CENTER AND STORED ELECTRONICALLY. THE COMMANDER WILL HAVE AVAILABLE TO HIM, THROUGH GENERAL AND SPECIFIC DISPLAY, THE OVERALL OR SEGMENT OF THE AIR SITUATION, AND HE WILL HAVE THAT INFORMATION PRACTICALLY INSTANTANEOUSLY.

SIMILAR INFORMATION WILL BE AVAILABLE TO AA OPERATIONS PERSONNEL STATIONED AT THE COMBAT CENTER. EARLY WARNING INFORMATION WILL BE FED ELECTRONICALLY, WHEN APPROPRIATE, TO THE AA OPERATIONS CENTER WHERE SUBSEQUENT DISSEMINATION TO LOWER ECHELONS CAN BE ACCOMPLISHED BY SOME SUCH SYSTEM AS THE 414A, NOW UNDER DEVELOPMENT BY THE SIGNAL CORPS. IT IS HERE AT THE COMBAT CENTER THAT THE THREAT IS EVALUATED AND PROPER WEAPONS ASSIGNED TO COMBAT THAT THREAT.

~~SECRET~~~~SECURITY INFORMATION~~

AIR DEFENSE BOUNDARIES—1955

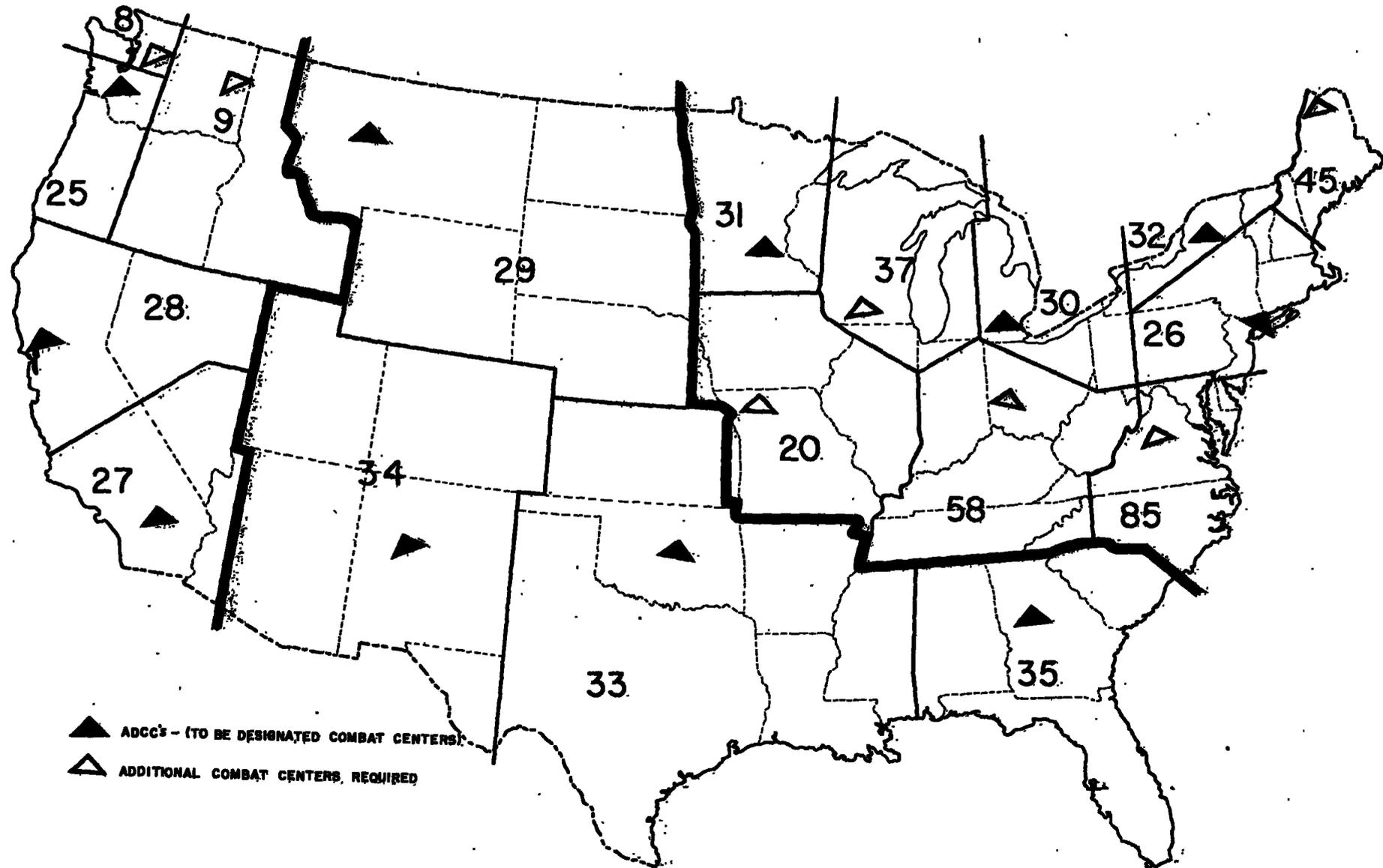

▲ ADCCs - (TO BE DESIGNATED COMBAT CENTERS)
△ ADDITIONAL COMBAT CENTERS, REQUIRED

~~SECURITY INFORMATION~~~~RESTRICTED~~COMMAND AND OPERATIONS

IT MAY BE HELPFUL AT THIS POINT TO DISCUSS WHAT THE ORGANIZATION OF THE AIR DEFENSE COMMAND MIGHT LOOK LIKE IN TERMS OF COMMAND AND OPERATIONS OF THE VARIOUS LEVELS IN 1955. THIS CHART SHOWS THE AIR DEFENSE COMMAND HEADQUARTERS, A TYPICAL AIR DEFENSE FORCE, THE COMBAT CENTER AT DIVISION LEVEL, AND TACTICAL UNITS. THE COMBAT CENTER IS THE HIGHEST ECHELON IN FULL CONTROL OF THE AIR BATTLE AND IS THE "HEART" OF THIS SYSTEM. THE COMMANDER HERE HAS UNDER HIS DIRECT COMMAND ALL THE SURVEILLANCE AND CONTROL FACILITIES TO EFFECTIVELY EMPLOY ALL ASSIGNED WEAPONS ON AN AREA BASIS.

THE FUNCTION OF THE DEFENSE COMMAND HEADQUARTERS IS COMMAND, FUTURE PLANNING AND PROGRAMMING, SUPERVISION, TESTING THE SYSTEM, AND PROVIDING TIMELY INTELLIGENCE TO THE DEFENSE FORCE COMMANDERS. DURING AN AIR BATTLE, THE FUNCTION WILL BE TO KEEP THE SITUATION CONTINUALLY EVALUATED IN ORDER TO SHIFT FORCES AT APPROPRIATE TIMES.

THE FUNCTION OF THE DEFENSE FORCE HEADQUARTERS IS SIMILAR TO THAT OF THE COMMAND HEADQUARTERS BUT IN FAR MORE DETAIL, WITH SPECIAL EMPHASIS ON THE CONDITIONS PECULIAR TO EACH AREA OF RESPONSIBILITY. THE USE OF FORCES OF OTHER COMMANDS IS PLANNED IN GREAT DETAIL AT THIS LEVEL.

THE FUNCTION OF THE COMBAT COMMANDER IS TO PROVIDE DEFENSE FOR TARGETS IN HIS AREA WITHIN THE CAPABILITY OF HIS FAMILY OF WEAPONS.

HERE ~~THE~~ SURVEILLANCE INFORMATION IS PRESENTED TO THE COMBAT COMMANDER DIRECTLY FROM DIRECTION AND SURVEILLANCE STATIONS. THIS DATA IS TRANSMITTED, PROCESSED AND DISPLAYED ELECTRONICALLY ON A NEAR INSTANTANEOUS BASIS. INFORMATION CONCERNING WEAPONS ASSIGNMENT AND USE FLOWS DOWNWARD FROM THE COMBAT CENTER.

THE FLOW OF INFORMATION UPWARD THROUGH EACH COMMAND ECHELON IS IN THE FORM OF A COMMANDER'S EVALUATED ESTIMATE.

55

~~RESTRICTED~~~~SECURITY INFORMATION~~

1955

COMMAND & OPERATIONS

ADVANCED PLANNING AND
COMMAND DECISIONS BASED
UPON INTELLIGENCE FROM
ALL SOURCES

COMMAND DECISIONS BASED
UPON GUIDANCE FROM HQ.
A D C, AND EVALUATED
INTELLIGENCE FROM THE
COMBAT CENTER

THREAT EVALUATION
WEAPON ASSIGNMENT

WEAPON UTILIZATION

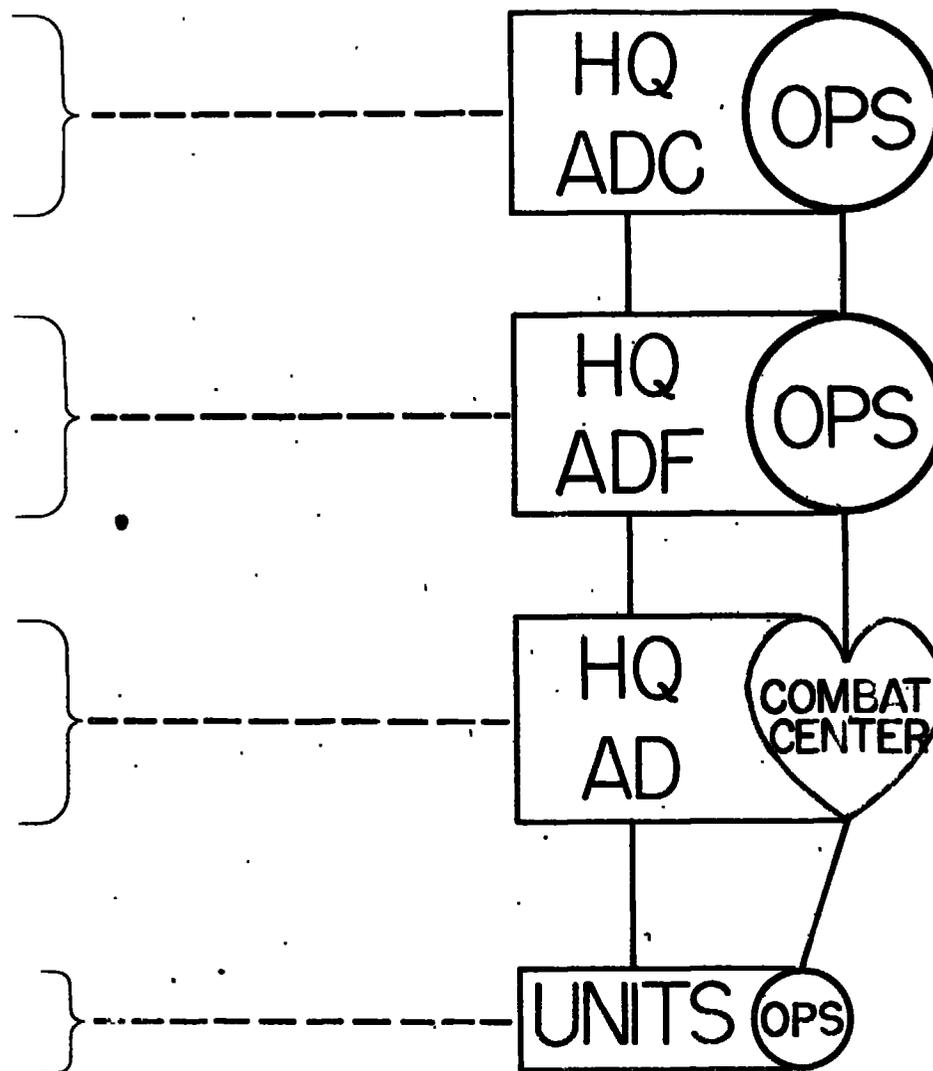

~~SECURITY INFORMATION~~~~SECRET~~PANORAMA

THIS CHART SHOWS A THUMBNAIL SKETCH OF A 1955 TYPE SECTOR IN OPERATION EMPLOYING ALL FACILITIES AVAILABLE FOR AIR DEFENSE. THIS SYSTEM WILL EMPLOY AIRBORNE EARLY WARNING AIRCRAFT, PICKET SHIPS, PASSIVE DETECTION EQUIPMENT, LAND BASED RADAR, ELECTRONIC COUNTERMEASURE EQUIPMENT, ALL AVAILABLE WEAPONS AND THE BASIC GROUND ENVIRONMENT FOR THE TIME PERIOD UNDER DISCUSSION OF 1955-1956.

SOME ASSUMPTIONS WILL BE NECESSARY AS TO THE HUNDREDS OF STRATEGIES AND THOUSANDS OF TACTICS THAT CAN BE USED BY THE ATTACKING FORCES. THEREFORE, WE WILL ASSUME A REASONABLE DIFFICULT ATTACK WHICH WILL REQUIRE THE COMPLETE AND COORDINATED DEFENSE EFFORT WITHIN THE SECTOR.

THE ATTACK VEHICLES WILL BE AIRCRAFT OF VARIOUS TYPES WITH SPEEDS UP TO 450 KNOTS, ATTACKING FROM THE DECK UP TO 45,000 FEET. THE ATTACK WILL OCCUR UNDER THE COVER OF NIGHT OR BAD WEATHER AND WILL INVOLVE SIMULTANEOUS PENETRATION OF THE DETECTION NET TOWARDS SELECTED TARGETS.

HERE IS PROBABLY WHAT WILL HAPPEN:

FIRST HOSTILE DETECTED BY AEW&C AND IDENTIFIED AS HOSTILE. COMBAT COMMANDER DECLARES AIR DEFENSE WARNING RED - INTERCEPT BEGINS - INNER DEFENSE ZONES ACTIVE - ALL AGENCIES AND SERVICES WARNED - ADC DECLARES EMERGENCY SECURITY CONTROL OF AIR TRAFFIC IN EFFECT - OTHER HOSTILES DETECTED - BROADCAST STATIONS CONTROLLED - OVERALL THREAT EVALUATED AT COMBAT CENTER - MORE INTERCEPTS BEGUN - AIR RAID SIRENS ARE WARNING PUBLIC - ALL FORCES MOVING TO ACTION READINESS - AEW AIRCRAFT AND PICKET VESSELS TRACKING HOSTILES AND DIRECTING INTERCEPTS - THREAT EVALUATED AS MASS ATTACK - ALL INTERCEPTORS COMMITTED - DECISION TO USE LONG RANGE MISSILES - MISSILES COMMITTED - INTERCEPTORS ARRIVE FROM ADJACENT SECTORS - ATTACKERS ARE JAMMING GROUND RADARS - COUNTERMEASURES TAKEN - JAMMING BEGINS AGAINST AIRCRAFT APPROACHING TARGETS - LOCAL WEAPONS ENGAGE IN ADDITION TO INTERCEPTORS AND LONG RANGE MISSILES - ADDITIONAL RAIDS DETECTED PENETRATING FRINGES OF RADAR COVER - INTERCEPTORS RECOMMITTED - HEAVIER RAIDS APPROACHING ADJACENT SECTOR - COMBAT OPS AT DEFENSE FORCE DIVERTS INTERCEPTORS TO ADJACENT SECTOR - SOME LONG RANGE MISSILES LAUNCHED FOR CONTROL IN ADJACENT SECTOR -

* * * * *

BUT WHAT CAUSES US SLEEPLESS NIGHTS IS THE WORRY THAT THE BATTLE WILL BEGIN BEFORE WE HAVE THIS COMPLETE SYSTEM.

56
~~SECRET~~

~~SECURITY INFORMATION~~

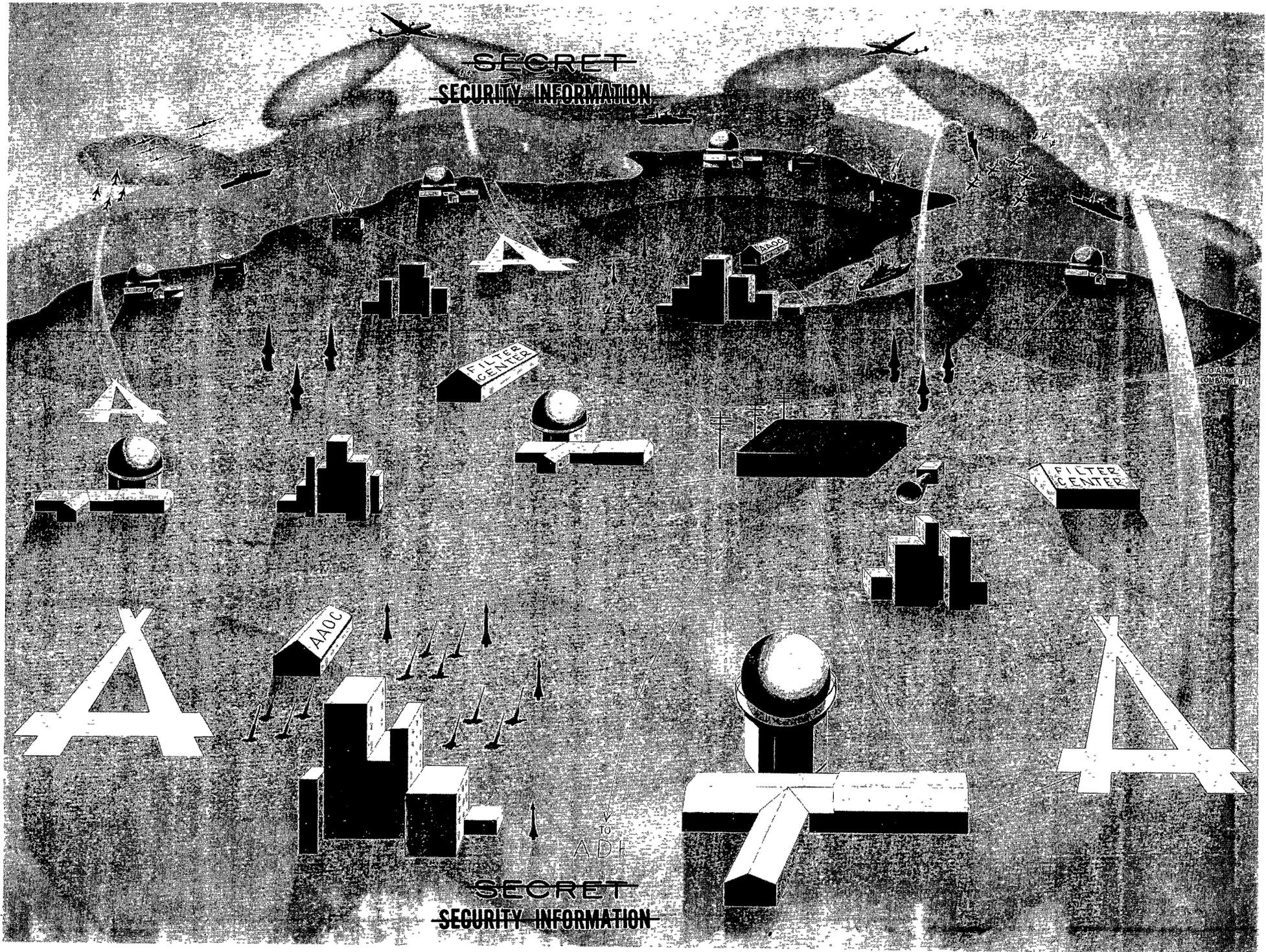

~~SECRET~~
~~SECURITY INFORMATION~~

~~SECURITY INFORMATION~~~~TOP SECRET~~KILL VS COST

BEFORE DISCUSSING THE MORE DISTANT FUTURE, LET'S SEE WHAT THIS SYSTEM IS WORTH IN COST AND EFFECTIVENESS. HERE SHOWN IS A COMPARISON OF KILL VERSUS COST. KILL IS IN PERCENT BEFORE BOMB RELEASE LINE, AND COST IN BILLIONS FOR OBTAINING SUCH KILL. THE TOP CURVE IS FOR ATTACKS AT HIGH ALTITUDE IN DAYLIGHT AND THE BOTTOM CURVE FOR LOW ALTITUDE ATTACKS AT NIGHT; THE TWO EXTREMES IN OUR AIR DEFENSE CAPABILITY. THIS CHART IS AN EXTRAPOLATION OF DATA FROM A DETAILED AIR DEFENSE STUDY RECENTLY COMPLETED BY HQ ADC. THIS STUDY WAS BASED UPON THE PROBABLE ENEMY THREAT FOR TIME PERIODS SHOWN; AND, DEFENSE FORCES THAT ARE PROGRAMMED FOR 1955 AND ANTICIPATED FOR 1957 ASSUMING SAME RELATIVE FUND APPROPRIATIONS AS NOW BEING RECEIVED FOR AIR DEFENSE. THE KILL AGAINST HIGH ALTITUDE DAY ATTACK INCREASES FROM ABOUT 18% IN 1952 TO ABOUT 50% BY 1957; THE KILL AGAINST NIGHT ATTACK INCREASES FROM ZERO TO ABOUT 45% IN 1957. WHILE THIS IS A TREMENDOUS INCREASE, AS YOU WILL SEE, THIS IS BY NO MEANS ADEQUATE.

57

~~TOP SECRET~~~~SECURITY INFORMATION~~

TOP SECRET

KILL VS COST

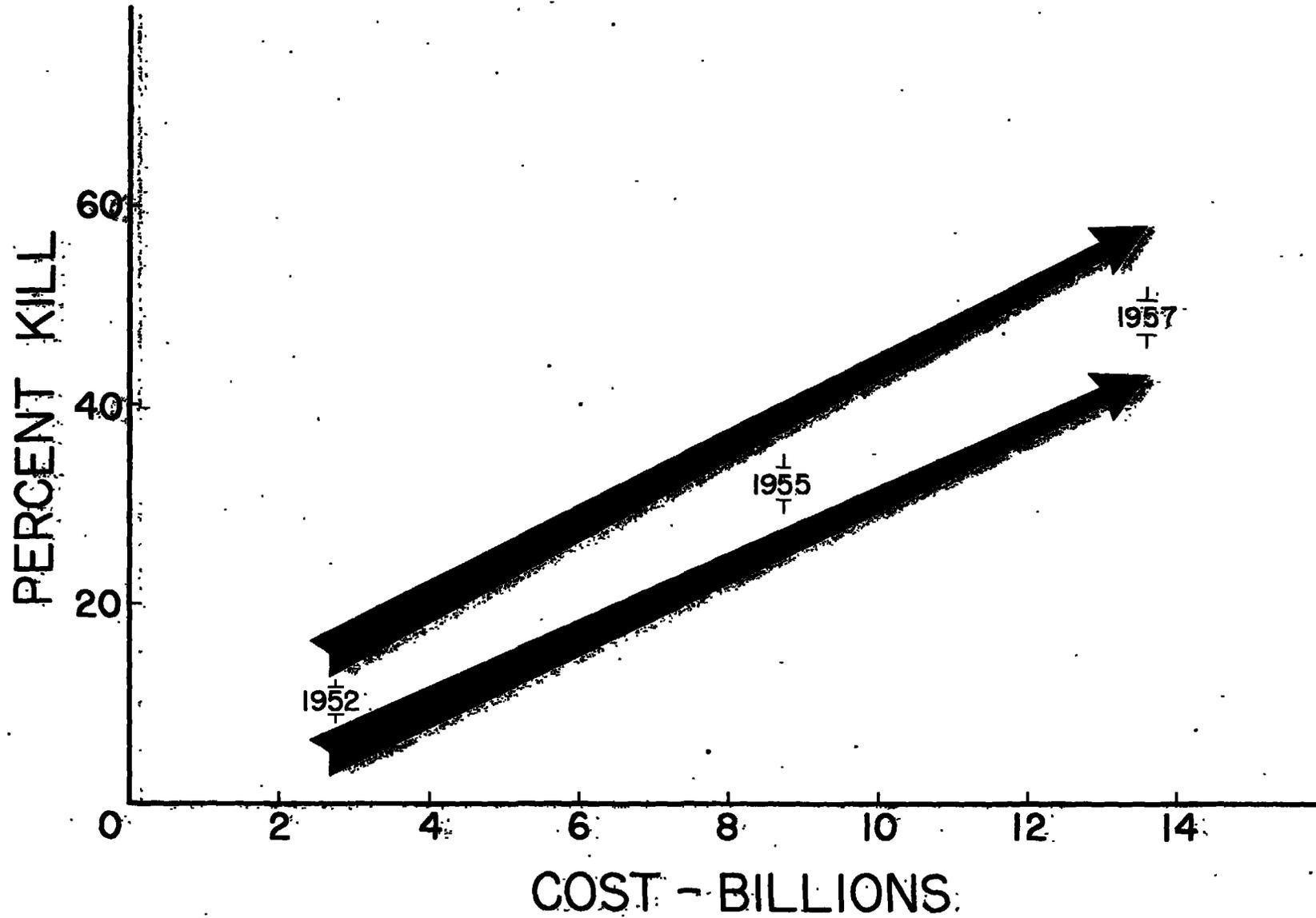

TOP SECRET

~~SECURITY INFORMATION~~~~TOP SECRET~~FUTURE THREAT

SO FAR WE'VE DISCUSSED THE AIR DEFENSE "PICTURE" UP TO THE 1955-57 TIME PERIOD.

NOW LET'S DO A LITTLE CRYSTAL BALL GAZING TO SEE WHAT CONSIDERATIONS ARE INVOLVED IN THE PERIOD 1957 AND 1960. I'LL BRIEFLY DISCUSS THE THREAT; SURVEILLANCE REQUIREMENTS, THE WEAPONS, AND LASTLY THE 64 DOLLAR QUESTION; HOW MUCH AIR DEFENSE DO WE NEED?

BY 1957 THE USSR CAN PRODUCE UP TO 1000 A-BOMBS OR THE EQUIVALENT; AND BY 1960 THIS MAY REACH 2000! DURING THE SAME TIME PERIODS HE WILL HAVE SUFFICIENT DELIVERY VEHICLES TO USE ANY AMOUNT OF HIS A-BOMB STOCK PILE HE FEELS IS REQUIRED TO KILL THE UNITED STATES. THE DELIVERY VEHICLES WILL BE DIFFERENT TYPES VARYING IN SIZE FROM THE SNARK TYPE MISSILE TO THE B-52 BOMBER; WITH SPEEDS RANGING FROM M .8 TO M 1.5; AND ATTACK ALTITUDES FROM THE DECK TO 55, OR SO, THOUSAND FEET. MISSILES LAUNCHED FROM SUBMARINES MAY BE USED. A SUCCESSFUL ATTACK WOULD BE CATASTROPHIC.

~~TOP SECRET~~~~SECURITY INFORMATION~~

~~TOP SECRET~~

FUTURE THREAT

1957



1500



1000

1960



2000

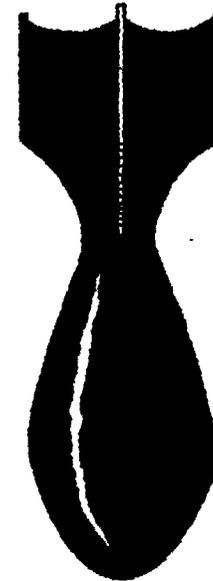

2000

~~TOP SECRET~~

~~SECURITY INFORMATION~~

FUTURE SURVEILLANCE

THIS SHOWS THE FUTURE SURVEILLANCE REQUIREMENTS, NOW IN THE SERIOUS PLANNING STAGE, TO PROVIDE ALERTING TIME REQUIRED TO EFFECTIVELY BEGIN COMBATING THE INCREASING THREAT.

THE LINE ACROSS THE NORTH IS THE DISTANT EARLY WARNING ZONE PROPOSAL OF PROJECT LINCOLN, TO PROVIDE THE MAXIMUM WARNING OF AN ATTACK EN ROUTE. FUNDS HAVE BEEN PROVIDED FOR INSTALLATION OF FOUR SITES IN THE MCKENSIE BAY AREA (OUTLINED IN BLACK BLOCK) FOR EXPERIMENT AND TEST OF EQUIPMENT FEASIBILITY, PRIOR TO COMMITMENT OF FUNDS AND EQUIPMENT FOR THE WHOLE LINE. NOTE THAT FLANKS MUST BE EXTENDED BY AIRBORNE RADAR AND PICKET VESSELS TO HAWAII AND SCOTLAND. SHOWN BY THE BROKEN LINES ARE THE PROPOSALS FOR "FENCE" TYPE DETECTORS. THESE EQUIPMENTS ARE RELATIVELY CHEAP, SIMPLE AND EFFECTIVE FROM 0 TO 80,000 FEET. THEY WILL WARN OF A PENETRATION OF THE LINE BY ANY AIRCRAFT. ALSO SHOWN IS THE RADAR COVERAGE OF THE AIR DEFENSE SYSTEMS REQUIRED TO TAKE COMBATIVE ACTION AGAINST THE ATTACK.

IT'S OBVIOUS NOW ~~WHERE~~ WE MUST BEGIN TO PLAN AIR DEFENSE OF THE NORTH AMERICAN CONTINENT RATHER THAN JUST THE CONTINENTAL U. S.

~~TOP SECRET~~

~~SECURITY INFORMATION~~

FUTURE SURVEILLANCE

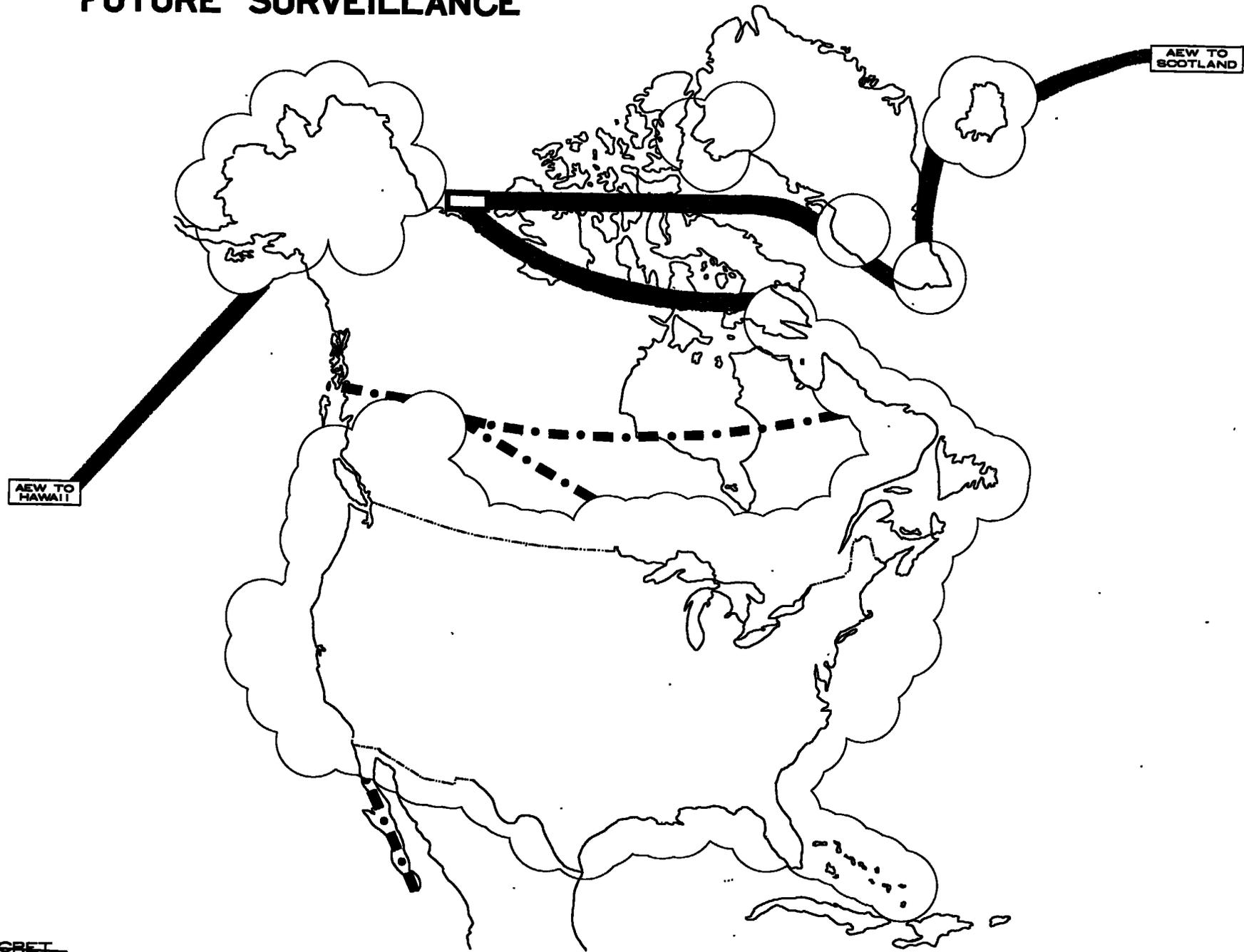

~~SECURITY INFORMATION~~

~~CONFIDENTIAL~~

FUTURE WEAPONS

(F-102)

NOW, LET'S LOOK AT THE WEAPONS THAT SHOULD BECOME AVAILABLE IN THE FUTURE.

FIRST, THE MANNED INTERCEPTORS.

THIS IS THE F-102, BUILT BY CONVAIR

60 DEGREE, TRUE DELTA CONFIGURATION, TURBO JET ENGINE

COMBAT WEIGHT 19,000 LBS.

MAXIMUM RATE OF CLIMB 45,000 FT. PER MINUTE

CEILING 60,000 FEET

MAXIMUM SPEED 1100 KNOTS

RADIUS OF ACTION ABOUT 500 NAUTICAL MILES

ARMAMENT - ROCKETS AND GUIDED MISSILES

THIS AIRCRAFT IS PROGRAMMED TO BE THE MAIN INTERCEPTOR DURING 1956-1958 PERIOD. THE FIRST ONE WILL FLY IN FALL 1953.

~~CONFIDENTIAL~~

~~SECURITY INFORMATION~~

F-102

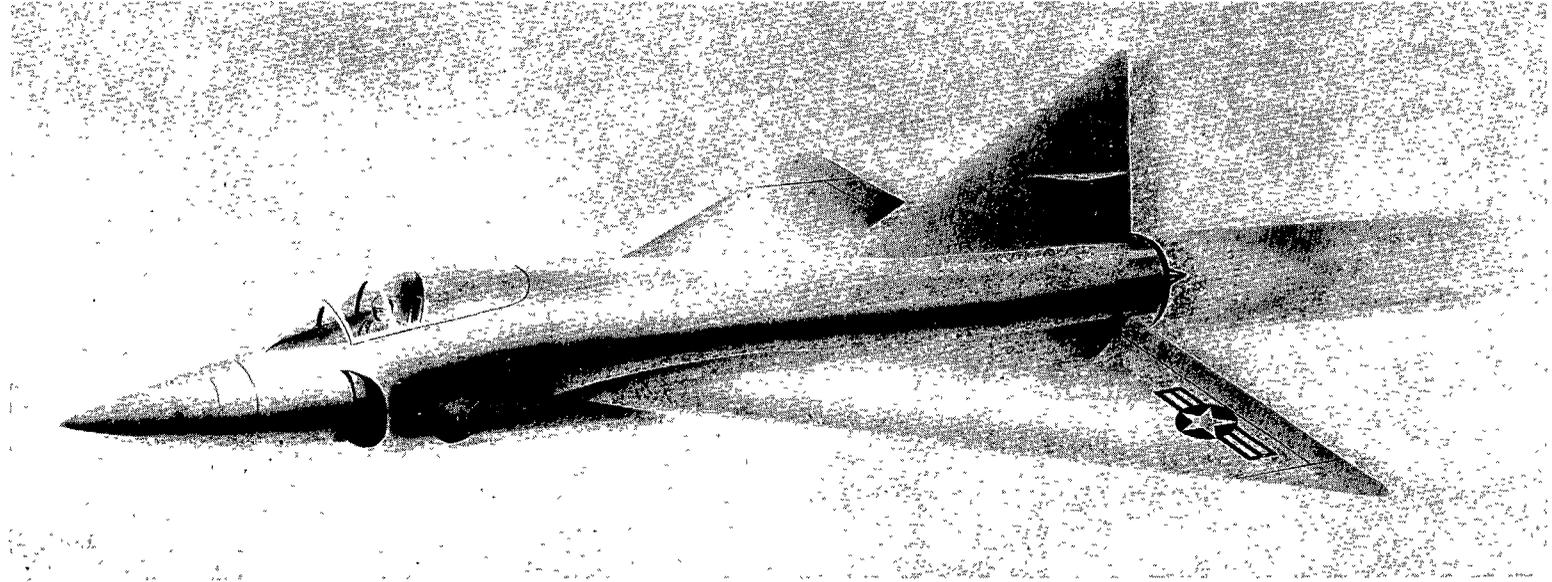

~~SECURITY INFORMATION~~

~~CONFIDENTIAL~~

FUTURE WEAPONS

(F-103)

THIS IS THE F-103 BUILT BY REPUBLIC:

DELTA CONFIGURATION, WITH TAIL SURFACES

TURBO JET AND RAM JET ENGINE

COMBAT WEIGHT - 25,000 LBS AT TAKEOFF

MAXIMUM RATE OF CLIMB - 60,000 FT. PER MINUTE

CEILING - OVER 60,000 FT.

MAXIMUM SPEED - 1800 KNOTS

RADIUS OF ACTION - ABOUT 400 NAUTICAL MILES

ARMAMENT - ROCKETS AND GUIDED MISSILES

THIS AIRCRAFT AT PRESENT IS PROGRAMMED TO FLY IN 1955 AS A RESEARCH VEHICLE.

~~CONFIDENTIAL~~

~~SECURITY INFORMATION~~

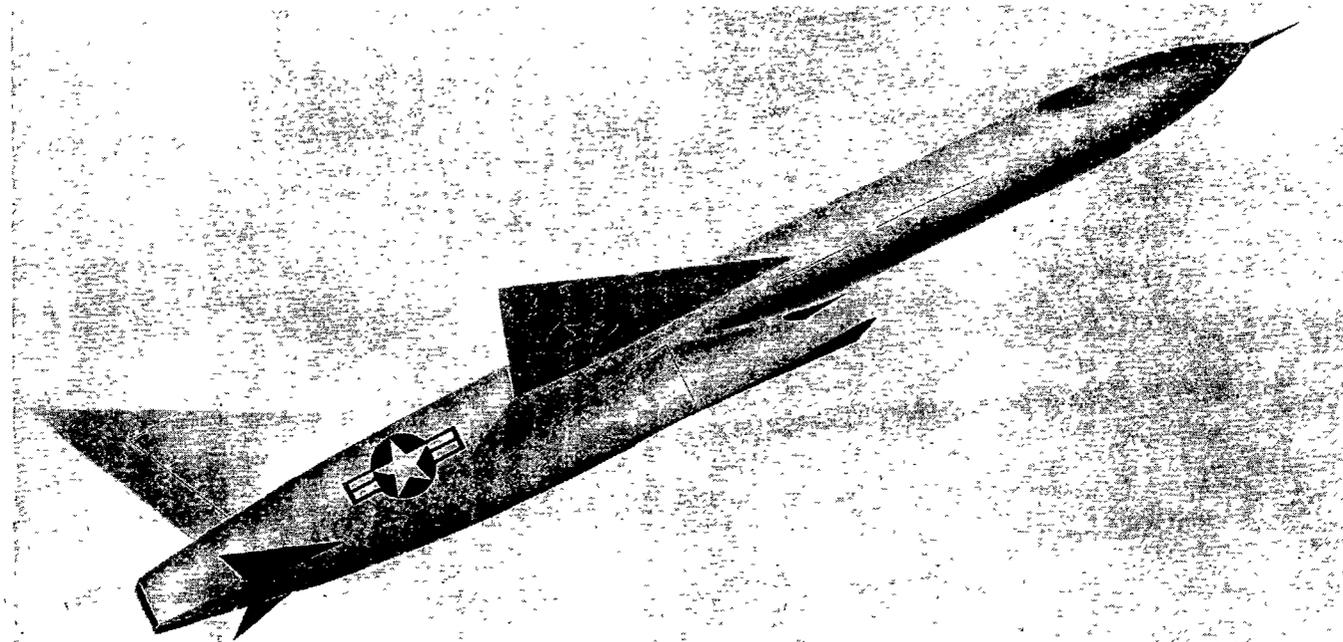

F-103

~~SECURITY INFORMATION~~~~SECRET~~FUTURE WEAPONS

(BOMARC)

HERE IS THE UNMANNED INTERCEPTOR UNDER DEVELOPMENT. IT IS THE BOMARC; A JOINT BOEING AIRCRAFT - UNIVERSITY OF MICHIGAN DEVELOPMENT.

3 FT. IN DIAMETER

35 FT. LONG

LIQUID ROCKET, AND RAM JET ENGINES

WEIGHT ABOUT 11,000 LBS. AT LAUNCHING

CEILING 80,000 FT.

SPEED 1500 KNOTS

RANGE - 150 IN EARLY MODELS AND 250 LATER.

THIS TACTICAL WEAPON SHOULD BE AVAILABLE IN NUMBERS BY 1957, AND IS TO BE PHASED INTO THE SYSTEM ALONG WITH INTERCEPTORS TO PROVIDE MASSED WEAPONS AGAINST MASS ATTACKS.

IT IS PLANNED TO HAVE ABOUT 3,000 OF THESE MISSILES BY 1960 ON 85 LAUNCHING SITES OF 30 MISSILES EACH. THEY WILL BE CONTROLLED BY BOMARC DIRECTORS IN THE AIR DEFENSE DIRECTION CENTERS.

62

~~SECRET~~~~SECURITY INFORMATION~~

BOMARC

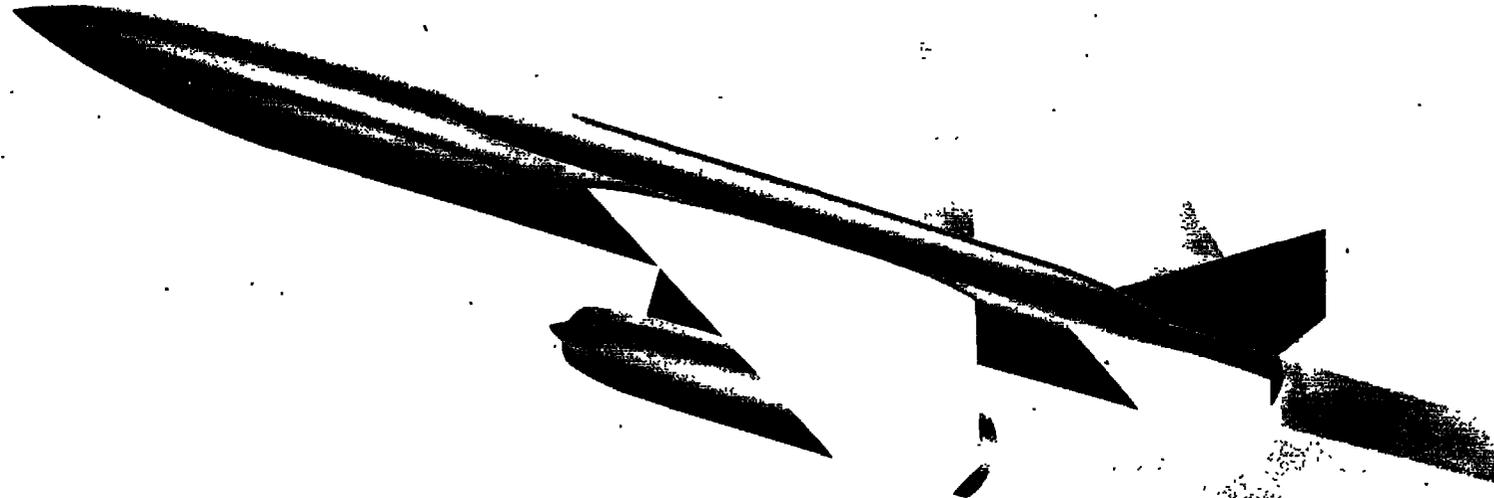

~~SECURITY INFORMATION~~~~SECRET~~FUTURE WEAPONS

(LOCAL TYPES)

TO PROVIDE FURTHER PROTECTION OF THE MOST CRITICAL TARGETS WE MUST HAVE, IN ADDITION TO INTERCEPTORS AND LONG RANGE MISSILES, WEAPONS OF A RELATIVELY SHORT RANGE, HIGH RATE OF FIRE, AND CAPABILITY OF HOMING ON TARGETS AT ALL ALTITUDES FROM POINT OF LAUNCHING. THIS MAY BE A LOGICAL FUTURE DEVELOPMENT OF THE NIKE TYPE MISSILE. THIS WOULD BE, IN EFFECT, THE LAST DITCH DEFENSIVE FIRE - TO BE ADDED TO THE ATTRITION BEING INFLICTED BY INTERCEPTORS AND LONG RANGE MISSILES.

ALL WEAPONS WE'VE DISCUSSED MUST BE SO DESIGNED TO BE ABLE TO COPE RAPIDLY AND ACCURATELY WITH ANY COUNTERMEASURES THAT CAN BE USED AGAINST THEM. THEY MUST ALSO BE ABLE TO OPERATE WITH MAXIMUM EFFECTIVENESS TOGETHER, WITHOUT DESTROYING EACH OTHER. THIS IS NOT AN IMPOSSIBLE REQUIREMENT.

63

~~SECRET~~~~SECURITY INFORMATION~~

SECRET

FUTURE WEAPONS

(LOCAL TYPES)

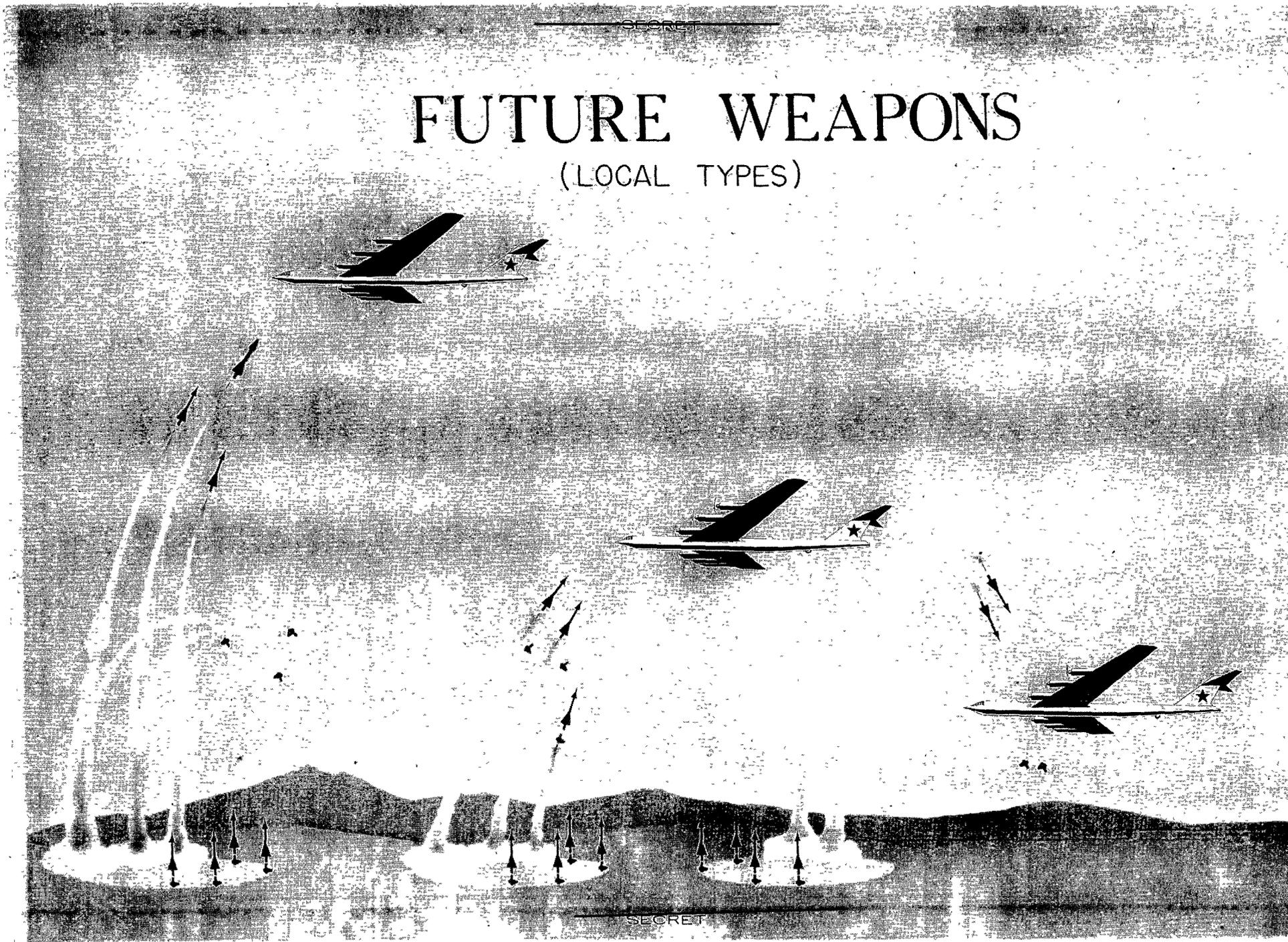

SECRET

~~SECURITY INFORMATION~~~~SECRET~~HOW MUCH AIR DEFENSE

RATHER THAN ATTEMPT A CONTROVERSIAL DISCUSSION ON HOW MANY BOMBS ON TARGET ARE REQUIRED TO KNOCK THE U. S. OUT OF EXISTENCE AS AN ADVERSARY; LET'S PICK AN ARBITRARY FIGURE OF 100. DEPENDING UPON BOMB YIELD THIS MAY BE ENOUGH IN ITSELF!

USING THIS FIGURE THEN, AND THE THREAT WE FACE IN THE FUTURE, AS SHOWN HERE, WE CAN SEE THAT OUR AIR DEFENSE CAPABILITY MUST BE IMPROVED IN TREMENDOUS MAGNITUDE TO PREVENT OBLITERATION OF OUR NATION. THESE ARE COLD, HARD FIGURES, WITH IMPACT HITHERTO UNREALIZED BY MANY OF US.

BUT WHEN WE CONSIDER WHAT CAN HAPPEN IF WE ARE HIT FIRST -- IT IS QUITE CLEAR OUR FUTURE AIR DEFENSE PLANNING MUST BE IN TERMS OF CONSIDERATION TO 100% KILL BEFORE BOMB RELEASE LINE ! WITHIN PRESENT NATIONAL POLICY IT WOULD BE FATAL TO ATTEMPT ANYTHING ELSE!

64

~~SECRET~~~~SECURITY INFORMATION~~

~~SECRET~~

HOW MUCH AIR DEFENSE

NUMBER OF USSR A — BOMBS	ESTIMATED AVAILABILITY	BOMB CARRIER KILL REQUIRED TO PREVENT 100 BOMBS ON U.S. TGTS.
300	1953-4	66% +
500	1955	80% +
1000	1957	90% +
2000	1959	95% +

~~SECRET~~

~~SECURITY INFORMATION~~~~SECRET~~FORCES REQUIRED IN FUTURE

THE NEXT QUESTION IS, HOW CAN YOU OBTAIN KILLS APPROACHING 100%. CONSIDERING THE THREAT WE'VE DISCUSSED, AND AFTER THE NECESSARY SURVEILLANCE AND CONTROL FACILITIES ARE PLANNED FOR, IT BECOMES PRIMARILY A MATTER OF NUMBERS OF WEAPONS. AN ESTIMATE, BASED UPON THE BEST AVAILABLE INFORMATION ON HAND IS SHOWN HERE.

BY 1960 WE WILL NEED ABOUT:

151 INTERCEPTOR SQUADRONS

160 BATTALIONS OF LOCAL MISSILES

AND 3000 BOMARC - - -

ALL EQUIPPED WITH THE MOST LETHAL ARMAMENT AND WARHEADS WE CAN DEVISE.

WHILE THESE REQUIREMENTS APPEAR TO BE IN THE "RIGHT BALL PARK", THEY CAN, OF COURSE, ONLY BE FIRMLY ESTIMATED AFTER CONSIDERABLY MORE ELABORATE WAR GAMING AND DETAILED TECHNICAL AND OPERATIONAL STUDIES.

~~SECRET~~~~SECURITY INFORMATION~~

~~SECRET~~

FORCES REQUIRED IN FUTURE (BY 1960)

1960

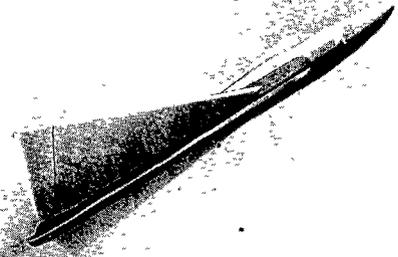

151 SQUADRONS

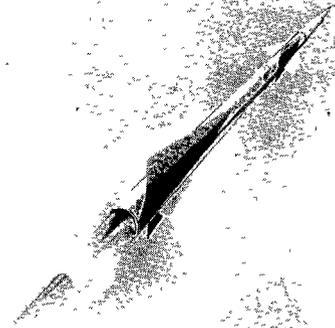

160 BATTALIONS

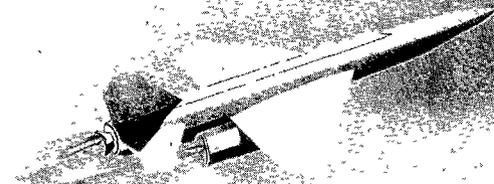

3000

NOW



39 SQUADRONS



55 BATTALIONS

NONE

BOMARC

~~SECRET~~

~~SECURITY INFORMATION~~~~SECRET~~FUTURE COST

AND NOW -- WHAT WILL THIS COST?

WELL, IN MONEY, IT LOOKS SOMETHING LIKE SHOWN ON THE CHART. - - -

THIS IS AN APPROXIMATION SHOWING AN ANNUAL EXPENDITURE FROM NOW ON OF 5 BILLION DOLLARS. THIS IS CAPITAL INVESTMENT AND OPERATING COST; AND WOULD INCLUDE THE COST OF THE AIR DEFENSE COMMAND, THE ARMY ANTI-AIRCRAFT COMMAND, THE COST OF AMC AND TRAINING COMMAND SUPPORT AND THE CONTRIBUTIONS OF OTHER COMMANDS AND SERVICES DIRECTLY RELATED TO THE AIR DEFENSE MISSION. AND IT WOULD INCLUDE SEVERAL HUNDRED MILLION ANNUALLY FOR RESEARCH, DEVELOPMENT AND ENGINEERING.

THIS WOULD BE ABOUT 10% OF THE U. S. TOTAL ANNUAL MILITARY EXPENDITURES.

66

~~SECRET~~~~SECURITY INFORMATION~~

~~SECRET~~

ANNUAL COST



NOW



FUTURE

~~SECRET~~

~~SECURITY INFORMATION~~~~SECRET~~BALLISTIC THREAT

ALL WE'VE DISCUSSED SO FAR HAS INVOLVED AIR DEFENSE ONLY AGAINST MANNED AND UNMANNED AIRCRAFT -- NO CONSIDERATION AT ALL OF THE THREAT OF AN INTERCONTINENTAL MISSILE WHICH APPROACHED ITS TARGET IN A NEAR VERTICAL TRAJECTORY AT SPEEDS OF AROUND MACH-10. THE PROBLEMS OF DETECTING THIS MISSILE, TRACKING IT AND KILLING IT, ONCE AIRBORNE, ARE STAGGERING. AND - VERY BLUNTLY - WE HAVE NO IDEA WHAT THE SOLUTION MIGHT BE.

END

67

~~SECRET~~~~SECURITY INFORMATION~~

BALLISTICS THREAT

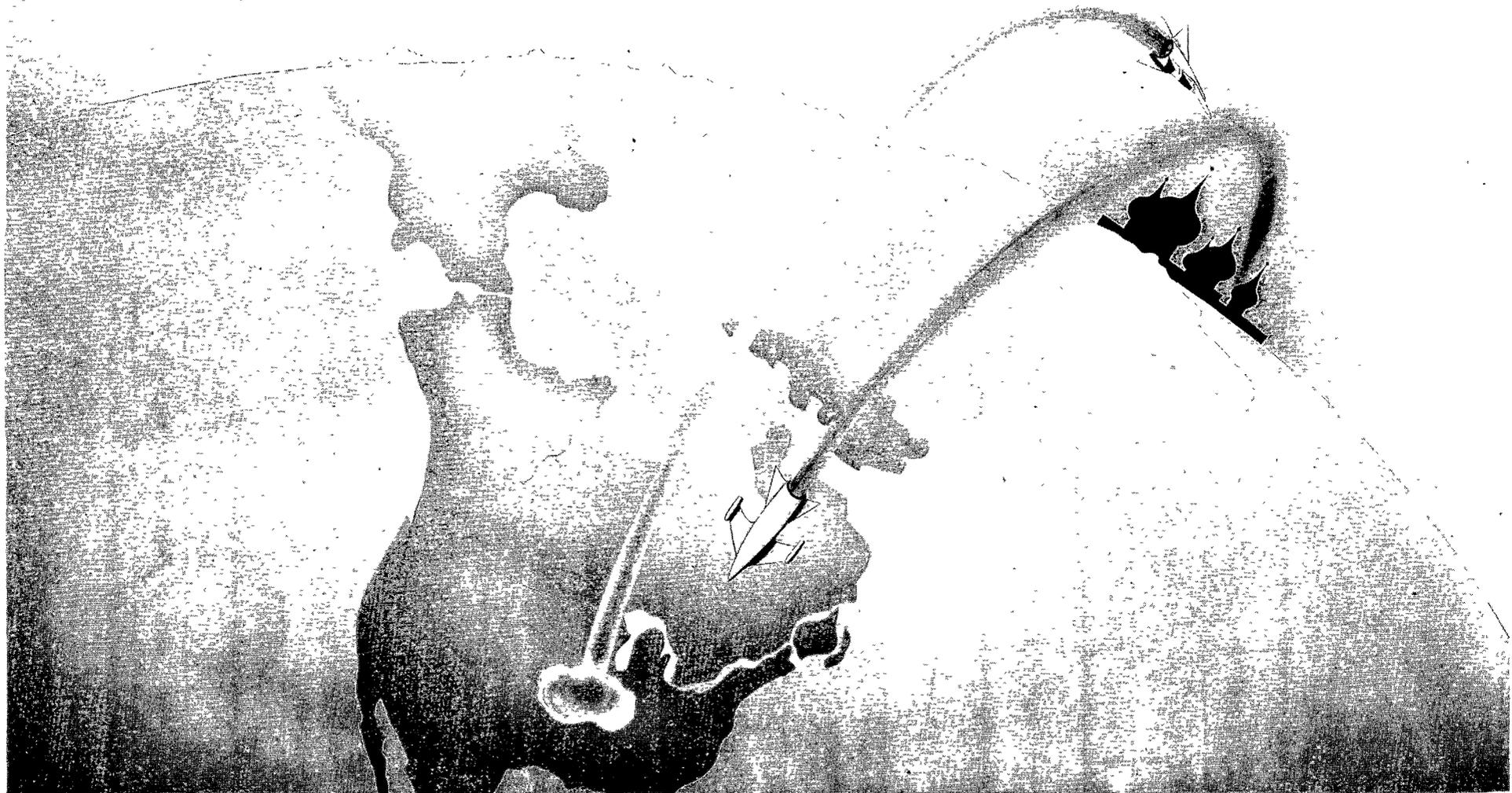

~~TOP SECRET — SECURITY INFORMATION~~

~~TOP SECRET — SECURITY INFORMATION~~

~~TOP SECRET~~
~~SECURITY INFORMATION~~

~~TOP SECRET~~
~~SECURITY INFORMATION~~